



Grain Handling

CORNER AUGER GRAIN CART MODEL 1060

Serial Number D64600100 & Higher

Part No. 2006218

Foreword

 This symbol identifies important safety messages. When you see it, read the message that follows and be alert to the possibility of personal injury.

Remember, safety instructions stated in this manual are for your protection. Read them carefully and follow them closely when working around or using this machine.

Read and study this manual completely before attempting to operate this implement. Take this manual to the field for handy reference when operating, adjusting, or servicing your machine.

When referenced, “Right-Hand” (RH) and “Left-Hand” (LH) side of the machine are determined by standing behind the machine and facing in the direction of travel.



Product Information

When ordering parts or when requesting further information or assistance, always give the following information:

- Machine name
- Model number
- Serial number

All products manufactured by Unverferth Mfg. Co., Inc. are warranted to be free from material and workmanship defects for one full year from time of consumer delivery. Your local dealer will gladly assist you with any warranty questions.

Please fill out and retain this portion for your records. The serial number plate is located on the frame as shown below.

Purchase Date _____ Model _____ Serial Number _____

Dealer _____ City _____

Dealer Contact _____ Phone _____



IMPORTANT

- *The information, specifications, and illustrations in the manual are based on information available at the time it was written. Due to continuing improvements in the design and manufacture of Unverferth products, all specifications and information contained herein are subject to change without notice.*

Table of Contents

**Section I
Safety**

General Hazard Information	1-2
Safety Decals	1-3
Following Safety Instructions	1-5
Before Servicing.....	1-6
Before Operating	1-6
During Operation	1-6
Before Transporting	1-7
During Transport.....	1-7
Driveline Safety.....	1-8
Pressurized Oil	1-9
Preparing for Emergencies.....	1-10
Wearing Protective Equipment.....	1-10

Table of Contents

**Section II
Set Up**

Set Up Checklist..... 2-2
Basic Cart Set Up - Folding Side Extension..... 2-3
Basic Cart Set Up - Transport Lighting and Markings 2-4
Basic Cart Set Up - SMV Emblem 2-4
Basic Cart Set Up - Auger Rest Retainer Removal 2-5
Basic Cart Set Up - Lamp Set Up..... 2-5
Basic Cart Set Up - Driveline Storage 2-5
Basic Cart Set Up - Wheel/Tire Set Up 2-6
Basic Cart Set Up - Adjustable Axle (Optional)..... 2-7

FOR TRACK INFORMATION, PLEASE REFER TO YOUR TRACK MANUAL.
FOR TARP INFORMATION, PLEASE REFER TO YOUR TARP MANUAL.
FOR SCALE INFORMATION, PLEASE REFER TO YOUR SCALE MANUAL.
FOR HYDRAULIC DRIVE INFORMATION, PLEASE REFER TO YOUR HYDRAULIC DRIVE MANUAL.

Table of Contents

**Section III
Operation**

Operating Checklist..... 3-2
Preparing Tractor..... 3-2
Preparing Cart - Hardware..... 3-3
Preparing Cart - Pivot Pins..... 3-3
Preparing Cart - Hitch..... 3-3
Preparing Cart - Auger..... 3-3
Preparing Cart - Soft Start System 3-4
Preparing Cart - Hydraulic System 3-4
Preparing Cart - Tires/Wheels 3-4
Lubrication..... 3-4
Hitching to Tractor - Drawbar Connection 3-5
Hitching to Tractor - Jack Usage 3-5
Hitching to Tractor - Transport Chain Connection 3-6
Hitching to Tractor - Hydraulic Connections 3-6
Hitching to Tractor - Hydraulic Connections for Hydraulic Drive 3-7
Hitching to Tractor - Electrical Connections 3-8
Towing..... 3-9
Auger Operation - PTO-Driven Auger..... 3-10
Optional Equipment - Hydraulic Drive..... 3-11

FOR TRACK INFORMATION, PLEASE REFER TO YOUR TRACK MANUAL.

FOR TARP INFORMATION, PLEASE REFER TO YOUR TARP MANUAL.

FOR SCALE INFORMATION, PLEASE REFER TO YOUR SCALE MANUAL.

FOR HYDRAULIC DRIVE INFORMATION, PLEASE REFER TO YOUR HYDRAULIC DRIVE MANUAL.

FOR UM520 AUTO DOOR OPERATING INFORMATION, PLEASE REFER TO YOUR
UM520 SCALE INDICATOR OPERATOR'S MANUAL.

Table of Contents

**Section IV
Maintenance**

Lubrication..... 4-2
Gearbox Lubrication 4-3
Seasonal Storage 4-3
Adjusting Cleanout Door 4-4
Auger Driveline..... 4-6
 Bearings..... 4-6
 Driveline Replacement..... 4-6
Auger System - Lower Auger Disassembly 4-9
Auger System - Lower Auger Assembly 4-10
Auger System - Upper Auger Disassembly..... 4-12
Auger System - Upper Auger Assembly 4-13
Auger System - Auger Flow Door Cylinder Replacement..... 4-14
Verify Telescoping PTO Shaft Length 4-17
PTO Shaft and Clutch..... 4-19
PTO Quick Disconnect 4-23
Electrical System Schematic..... 4-26
Hydraulic System Schematic..... 4-27
UM520 Auto Unload Manifold Schematic..... 4-28
Wheels and Tires - Wheel Nut Torque 4-29
Wheels and Tires - Tire Pressure..... 4-30
Wheels and Tires - Tire Warranty..... 4-31
Torque Chart - Hardware 4-32
Torque Chart - Hydraulic Fittings..... 4-34

FOR TRACK INFORMATION, PLEASE REFER TO YOUR TRACK MANUAL.

FOR TARP INFORMATION, PLEASE REFER TO YOUR TARP MANUAL.

FOR SCALE INFORMATION, PLEASE REFER TO YOUR SCALE MANUAL.

FOR HYDRAULIC DRIVE INFORMATION, PLEASE REFER TO YOUR HYDRAULIC DRIVE MANUAL.

Table of Contents

**Section V
Parts**

Final Assembly	5-2
Touch-Up Paint.....	5-3
Rigid Axle Single Wheel	5-4
Adjustable Axle Single Wheel	5-6
Adjustable Axle - Dual Wheels.....	5-8
Track Bundle Components	5-10
Track Axle Components	5-11
Hub - Rigid - Single Wheels	5-12
Hub - Adjustable Axle - Single Wheels	5-13
Hub - Adjustable Axle - Dual Wheels.....	5-14
Dual Wheels & Tires.....	5-15
Single Wheels & Tires	5-16
Decals	5-18
Sideboards.....	5-20
Electrical.....	5-22
Drive Components.....	5-24
Auger Components.....	5-26
Auger Fold Indicator	5-29
Cleanout Door Assembly.....	5-30
Flow Door Seals	5-31
Cylinders.....	5-32
Hydraulics.....	5-34
Directional Spout.....	5-36
PTO Assembly Shear-Bolt Clutch.....	5-38
PTO Assembly Friction Clutch.....	5-40
Friction Clutch.....	5-41
Shear-Bolt Clutch	5-42
45 Degree Gear Box	5-43
Driveline U-Joint Assembly	5-44
Video System Option	5-46

FOR TRACK INFORMATION, PLEASE REFER TO YOUR TRACK MANUAL.

FOR TARP INFORMATION, PLEASE REFER TO YOUR TARP MANUAL.

FOR SCALE INFORMATION, PLEASE REFER TO YOUR SCALE MANUAL.

FOR HYDRAULIC DRIVE INFORMATION, PLEASE REFER TO YOUR HYDRAULIC DRIVE MANUAL.

Section I Safety

General Hazard Information	1-2
Safety Decals	1-3
Following Safety Instructions	1-5
Before Servicing.....	1-6
Before Operating	1-6
During Operation.....	1-6
Before Transporting	1-7
During Transport.....	1-7
Driveline Safety.....	1-8
Pressurized Oil	1-9
Preparing for Emergencies.....	1-10
Wearing Protective Equipment.....	1-10

General Hazard Information

No accident-prevention program can be successful without the wholehearted cooperation of the person who is directly responsible for the operation of the equipment.

A large number of accidents can be prevented only by the operator anticipating the result before the accident is caused and doing something about it. No power-driven equipment, whether it be transportation or processing, whether it be on the highway, in the field, or in the industrial plant, can be safer than the person who is at the controls. If accidents are to be prevented--and they can be prevented--it will be done by the operators who accept the full measure of their responsibility.

It is true that the designer, the manufacturer, and the safety engineer can help; and they will help, but their combined efforts can be wiped out by a single careless act of the operator.

It is said that, "the best kind of a safety device is a careful operator." We, at Unverferth Mfg. Co., Inc. ask that you be that kind of operator.



**REMEMBER:
THINK SAFETY
A CAREFUL OPERATOR IS THE
BEST INSURANCE AGAINST AN
ACCIDENT!**

SIGNAL WORDS



INDICATES AN EXTREMELY HAZARDOUS SITUATION OR ACTION THAT WILL RESULT IN SERIOUS INJURY OR DEATH.



INDICATES A HAZARDOUS SITUATION OR ACTION THAT COULD RESULT IN SERIOUS INJURY OR DEATH.



INDICATES AN UNSAFE SITUATION OR ACTION THAT MAY RESULT IN PERSONAL INJURY.



Is used for instruction on operating, adjusting, or servicing a machine.

Safety Decals

⚠ WARNING

- REPLACE LOST, DAMAGED, PAINTED, OR UNREADABLE DECALS IMMEDIATELY. IF PARTS THAT HAVE DECALS ARE REPLACED, ALSO MAKE SURE TO INSTALL NEW DECALS. THESE DECALS INFORM AND REMIND THE OPERATOR WITH OPERATIONAL INFORMATION AND SAFETY MESSAGES.

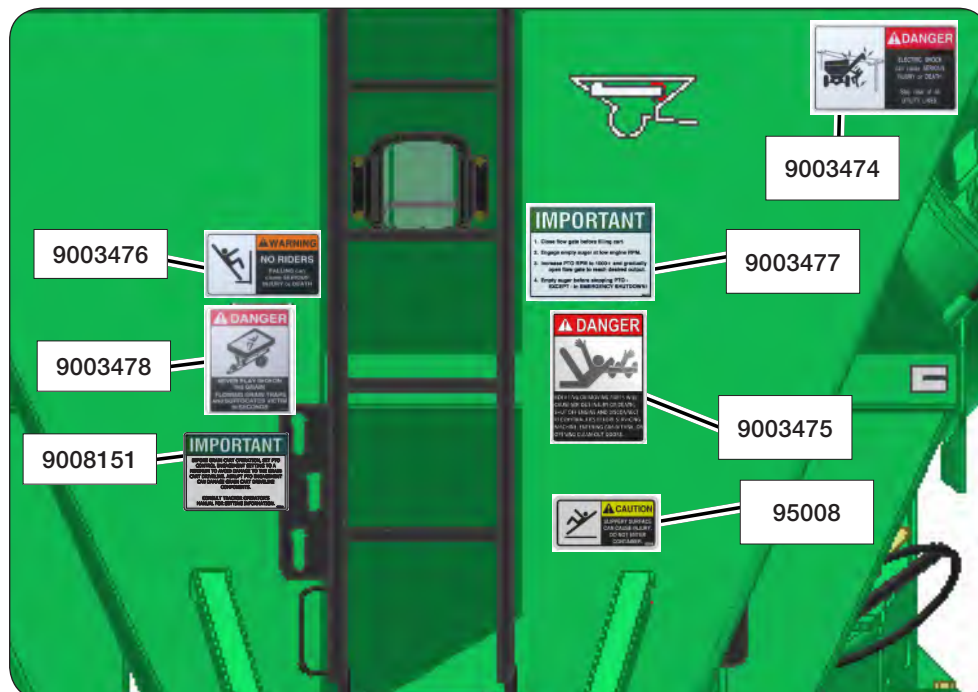

95046

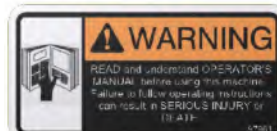

97961



94094

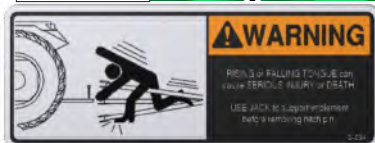

9003574

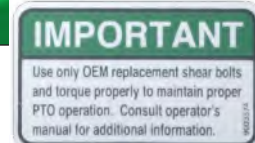

97575

Safety Decals (continued)

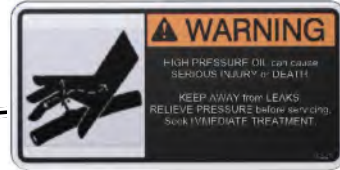

95445



95839

REFLECTORS
 9003125 (Fluorescent)
 9003126 (Red)
 9003127 (Amber)



9003475



TA510514



95046

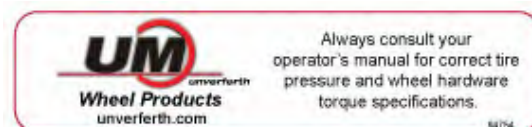
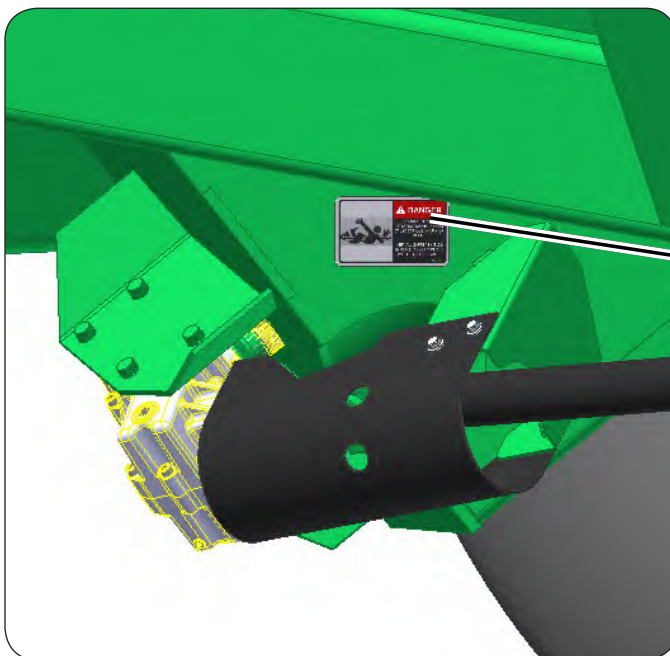

PART NO. 94754

Following Safety Instructions

- Read and understand this operator's manual before operating.



- All machinery should be operated only by trained and authorized personnel.

- To prevent machine damage, use only attachments and service parts approved by the manufacturer.

- Always shut tractor engine off and remove key before servicing.



- Avoid personal attire such as loose fitting clothing, shoestrings, drawstrings, pants cuffs, long hair, etc., that may become entangled in moving parts.

- Do not allow anyone to ride on the implement. Make sure everyone is clear before operating machine or towing vehicle.



- Never attempt to operate implement unless you are in the driver's seat.

- Never enter a cart containing grain. Flowing grain traps and suffocates victims in seconds.



Before Servicing

- Avoid working under an implement; however, if it becomes absolutely unavoidable, make sure the implement is safely blocked. 
- Ensure that all applicable safety decals are installed and legible.
- To prevent personal injury or death, always ensure that there are people who remain outside the cart to assist the person working inside, and that all safe workplace practices are followed. There is restricted mobility and limited exit paths when working inside the implement.
- Secure drawbar pin with safety lock and lock tractor drawbar in fixed position.
- Explosive separation of a tire and rim can cause serious injury or death. Only properly trained personnel should attempt to service a tire and wheel assembly.

Before Operating

- Do not stand between towing vehicle and implement during hitching.
- Always make certain everyone and everything is clear of the machine before beginning operation.
- Verify that all safety shields are in place and properly secured. 
- Ensure that all applicable safety decals are installed and legible.
- Secure drawbar pin with safety latch and lock tractor drawbar in fixed position.

During Operation

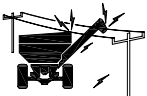
- Regulate speed to field conditions. Maintain complete control at all times.
- Never service or lubricate equipment when in operation.
- Keep away from overhead power lines. Electrical shock can cause serious injury or death. 
- Use extreme care when operating close to ditches, fences, or on hillsides.
- Do not leave towing vehicle unattended with engine running.

Before Transporting

- Secure transport chains to towing vehicle before transporting. **DO NOT** transport without chains.
- Install transport locks before transporting.
- Check for proper function of all available transport lights. Make sure that all reflectors are clean and in place on machine. Make sure the SMV emblem is visible to approaching traffic.
- This implement may not be equipped with brakes. Ensure that the towing vehicle has adequate weight and braking capacity to tow this unit.

During Transport

- Comply with all laws governing highway safety when moving machinery.
- Use transport lights as required by all laws to adequately warn operators of other vehicles.
- Use good judgment when transporting equipment on highways. Regulate speed to road conditions and maintain complete control.
- Maximum speed of implement should never exceed 20 mph. Do not exceed 10 mph during off-highway travel.
- Slow down before making sharp turns to avoid tipping. Drive slowly over rough ground and side slopes.
- Do not transport grain cart on roads while loaded.
- It is probable that this implement is taller, wider and longer than the towing vehicle. Become aware of and avoid all obstacles and hazards in the travel path of the equipment, such as power lines, ditches, etc.

Driveline Safety

- Do not allow children near equipment that is running or engaged.

- Do not exceed 1000 rpm PTO speed.
- Disengage the PTO, stop the tractor engine, and remove key from ignition before making inspections, or performing maintenance and repairs.
- Inspect the driveline, quick disconnect, overload shear-bolt limiter or clutch, and shielding often. Repair immediately. Use replacement parts and attaching hardware equivalent to the original equipment. Only alterations described in this manual for overall length adjustment are allowed. Any other alteration is prohibited.
- Avoid excessively long hardware or exposed and protruding parts which can snag and cause entanglement.
- Lubricate the driveline as recommended in the MAINTENANCE section.
- Keep hoses, wiring, ropes, etc. from dangling too close to the driveline.
- Install driveline and shields according to recommended lengths and attaching methods with recommended hardware. The driveline shield should rotate independently a full rotation and telescope freely. The retaining chain must be secured to the implement safety shield.
- Adjust drawbar to height recommended in tractor set up section.
- Be careful not to hit the driveline with tractor tires when turning.
- Check the length of the telescoping members to insure the driveline will not bottom out or separate when turning and/or going over rough terrain.
- Proper extended and collapsed lengths of the telescoping PTO shaft must be verified before first operation with each and every tractor. If the extended length of the PTO shaft is insufficient, it may become uncoupled or bottom out when turning and/or going over rough terrain which will cause serious injury or death from contact with uncontrolled flailing of PTO shaft assembly components.

Pressurized Oil

- Relieve pressure before disconnecting hydraulic lines from tractor, loosening any hydraulic fittings or servicing hydraulic system. See hydraulic power unit manual for procedure to relieve pressure.
- High-pressure fluids can penetrate the skin and cause serious injury or death. Use cardboard or wood to detect leaks in the hydraulic system. Seek medical treatment immediately if injured by high-pressure fluids. 
- Hydraulic system must be purged of air before operating to prevent serious injury or death.
- Do not bend or strike high-pressure lines. Do not install bent or damaged tubes or hoses.
- Repair all oil leaks. Leaks can cause fires, personal injury, and environmental damage.
- Route hoses and lines carefully to prevent premature failure due to kinking and rubbing against other parts. Make sure that all clamps, guards and shields are installed correctly.
- Check hydraulic hoses and tubes carefully. Replace components as necessary if any of the following conditions are found:
 - End fittings damaged, displaced, or leaking.
 - Outer covering chafed/cut or wire reinforcing exposed.
 - Outer covering ballooning locally.
 - Evidence of kinking or crushing of the flexible part of a hose.

Preparing for Emergencies

- Keep a first aid kit and properly rated fire extinguisher nearby.



- Keep emergency numbers for fire, rescue, and poison control personnel near the phone.



Wearing Protective Equipment

- Wear clothing and personal protective equipment appropriate for the job.



- Wear steel-toed shoes when operating.



- Wear hearing protection when exposed to loud noises.



- Do not wear additional hearing impairing devices such as radio headphones, etc.



Section II Set Up

Set Up Checklist.....	2-2
Basic Cart Set Up - Folding Side Extension.....	2-3
Basic Cart Set Up - Transport Lighting and Markings.....	2-4
Basic Cart Set Up - SMV Emblem.....	2-4
Basic Cart Set Up - Auger Rest Retainer Removal.....	2-5
Basic Cart Set Up - Lamp Set Up.....	2-5
Basic Cart Set Up - Driveline Storage.....	2-5
Basic Cart Set Up - Wheel/Tire Set Up.....	2-6
Basic Cart Set Up - Adjustable Axle (Optional).....	2-7

FOR TRACK INFORMATION, PLEASE REFER TO YOUR TRACK MANUAL.

FOR TARP INFORMATION, PLEASE REFER TO YOUR TARP MANUAL.

FOR SCALE INFORMATION, PLEASE REFER TO YOUR SCALE MANUAL.

FOR HYDRAULIC DRIVE INFORMATION, PLEASE REFER TO YOUR HYDRAULIC DRIVE MANUAL.

Set Up Checklist

After the cart has been completely assembled, use the following checklist and inspect the cart. Check off each item as it is found satisfactory or after proper adjustment is made.

- Torque wheel nuts and check tire pressure as specified in MAINTENANCE section.
- Axles are adjusted from shipping position to desired operating position. (If Applicable)
- Tires are inflated to specified air pressure. (If Applicable)
- All grease fittings have been lubricated and gearbox oil level checked.
- Check cleanout door assembly play or movement. See maintenance section for adjustment procedure.
- Check to be sure all safety decals are correctly located and legible. Replace if damaged.
- Check to be sure all reflective decals are correctly located.
- Check to be sure SMV decal is in place and shipping cover removed.
- Check to be sure transport lights are working properly.
- Check PTO. See “Verify Telescoping PTO Shaft Length” in MAINTENANCE section.
- Check to be sure screens over auger are in place and properly secured.
- Transport chains are properly installed and hardware is torqued to specification. See “Transport Chain Connection” in OPERATION section.
- Set tractor PTO control engagement setting to a minimum, refer to tractor operators manual for setting information.
- Paint all parts scratched in shipment.
- Test run the augers. See “Auger Operation” in OPERATION section.

Basic Set Up

Folding Side Extensions

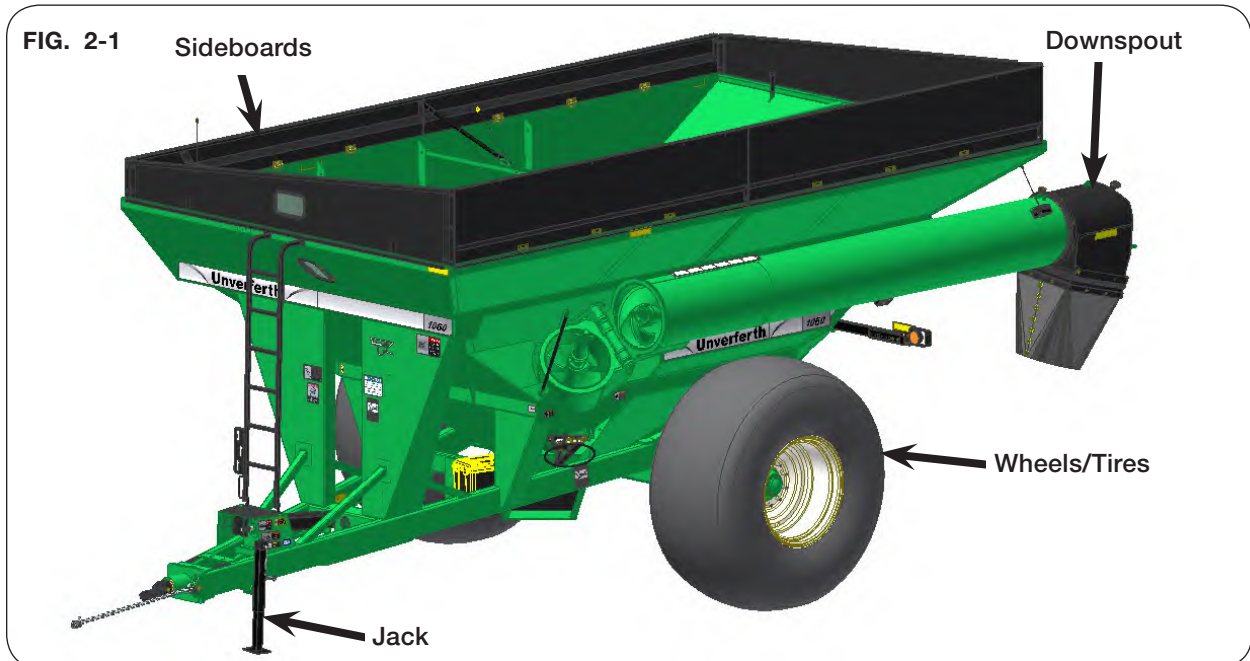

Due to shipping requirements and various dealer-installed options, some initial cart set up will be required after it arrives from the factory. Use the following procedures as needed for initial cart set up.

⚠ WARNING

- TO PREVENT PERSONAL INJURY OR DEATH, ALWAYS ENSURE THAT THERE ARE PEOPLE WHO REMAIN OUTSIDE THE CART TO ASSIST THE PERSON WORKING INSIDE, AND THAT ALL SAFE WORKPLACE PRACTICES ARE FOLLOWED. THERE IS RESTRICTED MOBILITY AND LIMITED EXIT PATHS WHEN WORKING INSIDE THE IMPLEMENT.
- KEEP HANDS CLEAR OF PINCH POINT AREAS.
- EYE PROTECTION AND OTHER APPROPRIATE PERSONAL PROTECTIVE EQUIPMENT MUST BE WORN WHILE SERVICING IMPLEMENT.

1. Rotate extensions up into position and secure at corner holes. Assemble extension panel bases to top edge of hopper with included fasteners.
2. Attach center support hardware.
3. Tighten all hardware, including hinge bolts.
4. Install hopper light. Mount in front right corner.

FIG. 2-2

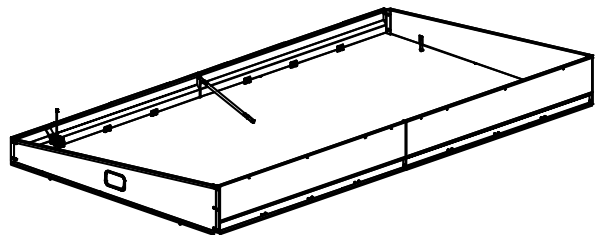

Basic Set Up (continued)

Transport Lighting and Markings

NOTE: Unverferth Manufacturing has designed the transport lighting and marking kit to meet United States federal law and ASABE standards at the time of manufacture. Machine modifications, including additional features or changes to the intended configurations, may require updates to the lighting and marking as well.

Compliance with all laws are the responsibility of the operator at the time of travel.

Please see federal regulation 49 CFR 562; available at www.govinfo.gov for US federal law requirements.

See your Unverferth dealer for additional brackets, reflectors, or lights to meet your requirements.

Lamp Set Up

Pivot lamp extension arms into position at sides of cart. The lamp bracket width is adjustable, if necessary, adjust lamp mount position to achieve dimension shown. Ensure that the brackets are adjusted such that the reflectors are no more than 16" from outer edge of the tires. Be sure that amber reflector is facing the front of the cart (some lights on certain cart models will be flipped down for shipping).

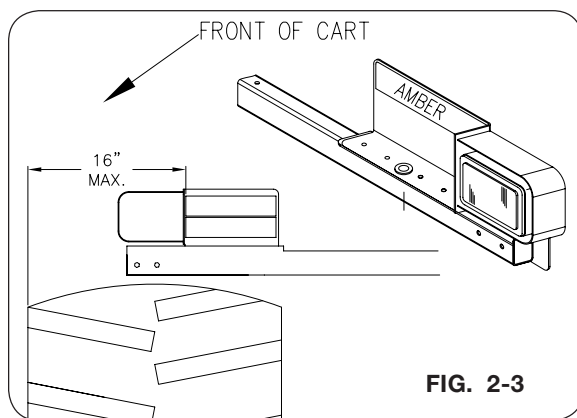

SMV Emblem

Before the cart is used the reflective surface of the SMV must face rearward. This may require removal of film protecting the reflective surface or removing and reinstallation of the SMV. When reinstalling the SMV make sure that it is mounted with the wide part of the SMV at the bottom.

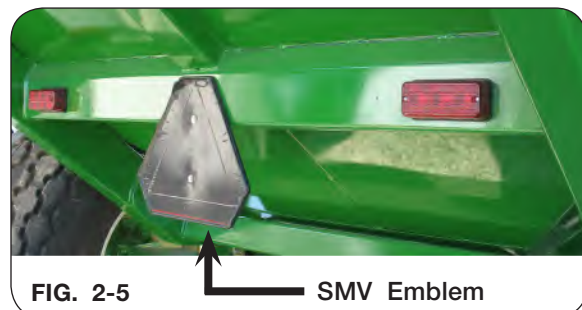

Basic Set Up (continued)

Auger Rest Retainer Removal

Remove the retainer located on the upper auger rest at the back of the cart, before folding out the upper auger tube.

IMPORTANT

- *Upper auger retainer must be removed before operating upper auger tube. Failure to remove retainer will result in damage to the upper auger tube.*



FIG. 2-6



FIG. 2-7

Driveline Storage

Storage brackets are located on the inside right frame rail. Secure the PTO shaft to these brackets for extended transporting or seasonal storage.

IMPORTANT

- *Remove and store the complete PTO before towing grain cart behind a delivery truck. Interference could occur when turning resulting in damage to PTO and cart.*

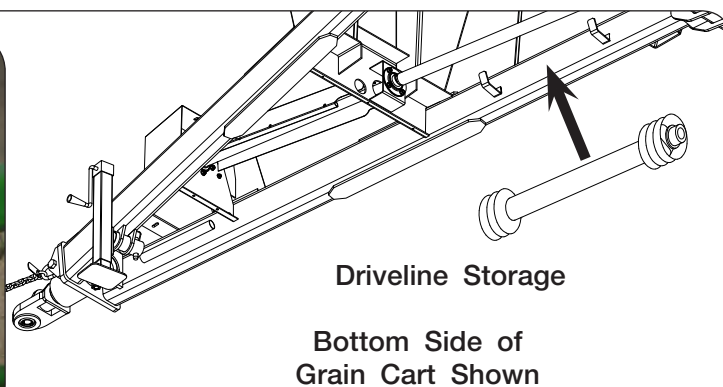

FIG. 2-8

Basic Set Up (continued)

Wheel/Tire Set Up

Tire Pressure

Tire pressure must be verified before first use and adjusted as necessary. Refer to maintenance section of this manual for information on tire pressure.

Wheel Nuts



CAUTION

- **IMPROPERLY TORQUED WHEEL NUTS/BOLTS CAN CAUSE A LOSS OF IMPLEMENT CONTROL AND MACHINE DAMAGE. WHEEL NUTS/BOLTS MUST BE CHECKED REGULARLY. SEE TORQUE PAGE IN THE “MAINTENANCE” SECTION FOR PROPER WHEEL NUT/BOLT SPECIFICATIONS. WARRANTY DOES NOT COVER FAILURES CAUSED BY IMPROPERLY TORQUED WHEEL NUTS/BOLTS.**

IMPORTANT

- *Installing wheels without the proper inset could result in hub or spindle failure. This will cause substantial damage to cart.*

Dual Wheel Installation

Align the dual wheels on the one side of the cart. Place the guide pin in the guide hole. Then, using the guide pin, seat the outer reinforcing ring into position. Secure the wheel and reinforcing ring with the lock washers and bolts provided. Refer to the “MAINTENANCE” section for proper torque requirements.

Basic Set Up (continued)

Adjustable Axle (Optional)

⚠ WARNING

- **FALLING OBJECTS CAN CAUSE SERIOUS INJURY OR DEATH. DO NOT WORK UNDER THE MACHINE AT ANY TIME WHILE BEING HOISTED. BE SURE ALL LIFTING DEVICES AND SUPPORTS ARE RATED FOR THE LOADS BEING HOISTED. THESE ASSEMBLY INSTRUCTIONS WILL REQUIRE SAFE LIFTING DEVICES UP TO 16,000 LBS. SPECIFIC LOAD RATINGS FOR INDIVIDUAL LOADS WILL BE GIVEN AT THE APPROPRIATE TIME IN THE INSTRUCTIONS.**
- **EYE PROTECTION AND OTHER APPROPRIATE PERSONAL PROTECTIVE EQUIPMENT MUST BE WORN WHILE SERVICING IMPLEMENT.**
- **KEEP HANDS CLEAR OF PINCH POINT AREAS.**
- **TIPPING OR MOVEMENT OF THE MACHINE CAN CAUSE SERIOUS INJURY OR DEATH. BE SURE MACHINE IS SECURELY BLOCKED.**

1. Hitch cart to tractor. Park the empty unit on a firm, level surface. Set the tractor's parking brake, shut-off engine and remove the ignition key.
2. Using a safe lifting device rated for a minimum of 8 tons and supports rated at 4 tons minimum, raise the cart and place supports under the axle near the axle clamps.
3. Loosen axle extension clamp and axle gauge bolts. Do not remove.

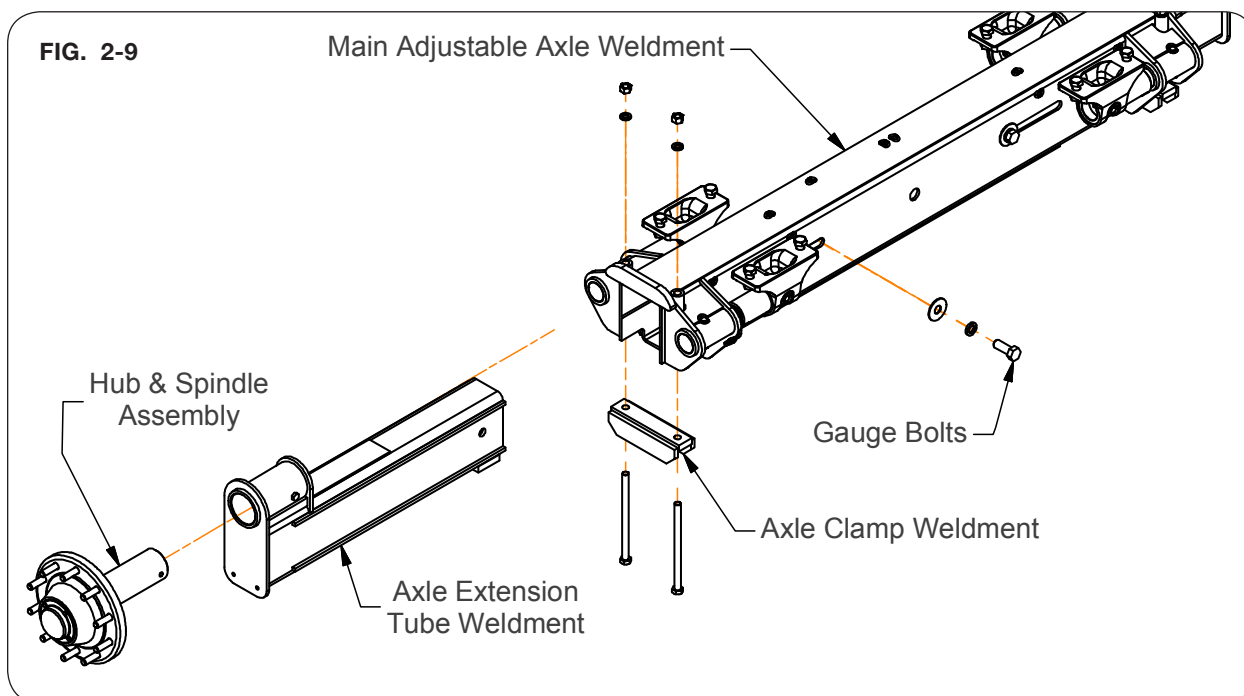
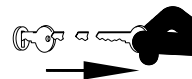

Basic Set Up (continued)

Adjustable Axle (Optional)

- Slide extensions to desired tire gauge spacing. Axle extensions should be extended equally. Refer to chart below and FIG. 2-10.

Tire Size	Slide Out Distance (From end of the main axle tube to inside of the extension weldment end cap plate.)	Distance Hub Flange to Hub Flange	Distance End to End
900/65R32	11 1/4"	134"	145"
900/70R32	12 1/4"	136"	147"
1050/50R32	13 1/4"	138"	149"
1250/50R32	20 1/4"	152"	163"

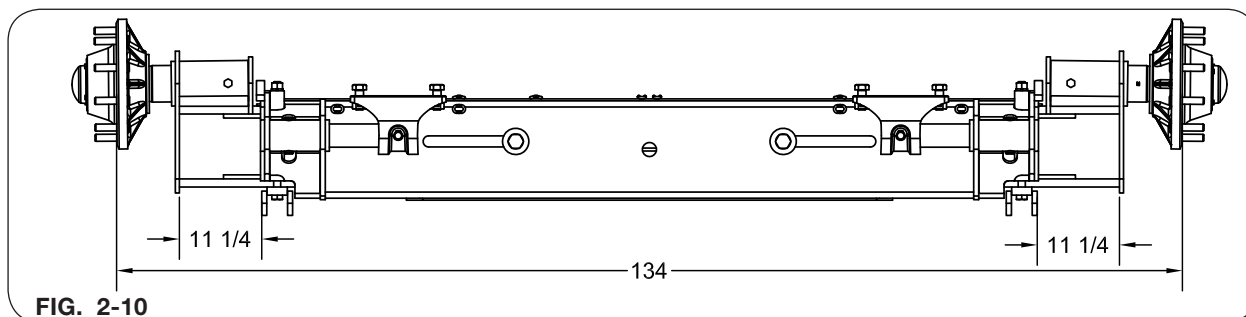

FIG. 2-10

- Tighten axle gauge bolts followed by axle clamp bolts, refer to MAINTENANCE section for proper torque specifications. (FIG. 2-11)

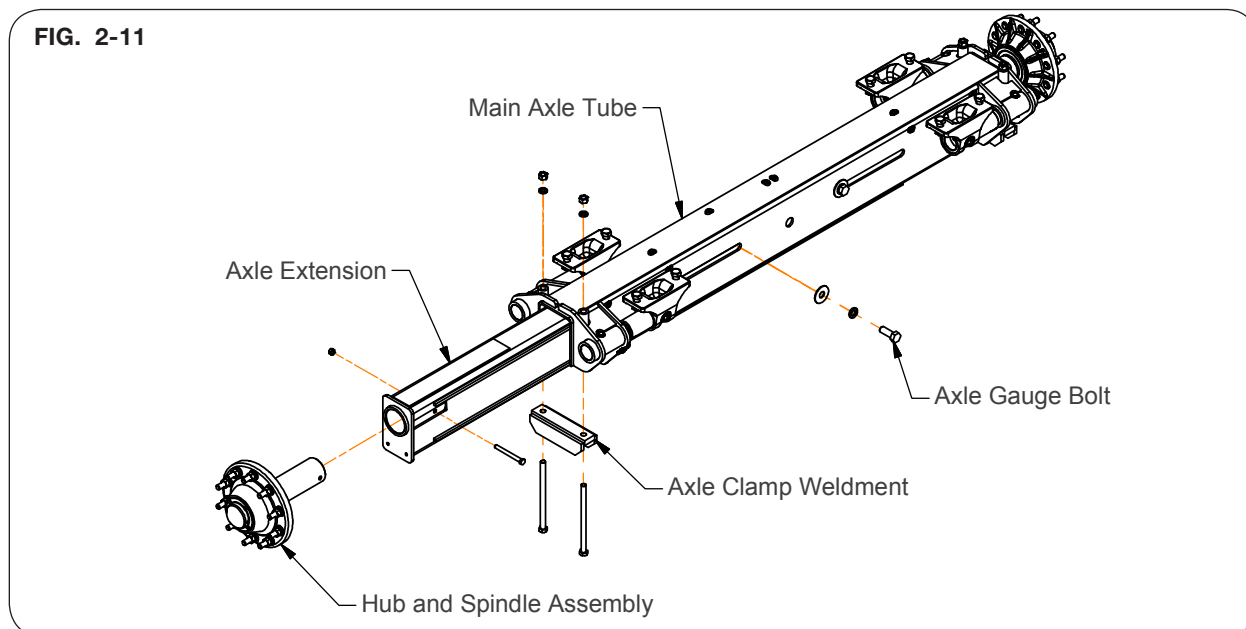

FIG. 2-11

- Remove supports and lower cart to ground.

NOTE: If tires are positioned at a wider tread width, make sure lights are also moved out to within 16" of the outside of tires.

Section III Operation

Operating Checklist.....	3-2
Preparing Tractor.....	3-2
Preparing Cart - Hardware.....	3-3
Preparing Cart - Pivot Pins.....	3-3
Preparing Cart - Hitch.....	3-3
Preparing Cart - Auger.....	3-3
Preparing Cart - Soft Start System.....	3-4
Preparing Cart - Hydraulic System.....	3-4
Preparing Cart - Tires/Wheels.....	3-4
Lubrication.....	3-4
Hitching to Tractor - Drawbar Connection.....	3-5
Hitching to Tractor - Jack Usage.....	3-5
Hitching to Tractor - Transport Chain Connection.....	3-6
Hitching to Tractor - Hydraulic Connections.....	3-6
Hitching to Tractor - Hydraulic Connections for Hydraulic Drive.....	3-7
Hitching to Tractor - Electrical Connections.....	3-8
Towing.....	3-9
Auger Operation - PTO-Driven Auger.....	3-10
Optional Equipment - Hydraulic Drive.....	3-11

FOR TRACK INFORMATION, PLEASE REFER TO YOUR TRACK MANUAL.

FOR TARP INFORMATION, PLEASE REFER TO YOUR TARP MANUAL.

FOR SCALE INFORMATION, PLEASE REFER TO YOUR SCALE MANUAL.

FOR HYDRAULIC DRIVE INFORMATION, PLEASE REFER TO YOUR HYDRAULIC DRIVE MANUAL.

FOR UM520 AUTO DOOR OPERATING INFORMATION, PLEASE REFER TO YOUR
UM520 SCALE INDICATOR OPERATOR'S MANUAL.

Operating Checklist

- Read and understand all safety precautions before operating cart.
- Check axle spacing to be sure axle is adjusted from shipping position to desired operating width. (If Applicable)
- Check to be sure all the reflective decals and the SMV sign are clearly visible with the cart attached to the tractor. Check to be sure the transport lights are in working condition. Check and follow federal, state/provincial and local regulations before towing on a road or highway.
- Check to be sure the hitch height when attached to the tractor is sufficient to prevent severe bends in PTO U-joint angles.
- Check to be sure PTO is correct length for making turns and operating on uneven terrain. See “Verify Telescoping PTO Shaft Length” in MAINTENANCE section.
- Torque wheel nuts and check tire pressure as specified in MAINTENANCE section.
- Transport chains are properly installed and hardware is torqued to specification. See “Transport Chain Connection” in OPERATION section.
- Check to be sure all screens and safety shields are in place.
- Check to be sure recommended lubrication procedures are being followed.
- Check operation and functionality of flow door, flow door indicator, auger fold, and auger pivot.
- Set tractor PTO control engagement setting to a minimum, refer to tractor operators manual for setting information.
- Test run the augers. See “Auger Operation” in OPERATION section.

Preparing Tractor

Before operating cart, read the tractor Operator’s Manual and gain an understanding of its safe methods of operation.

Check the tractor brakes and transport lights. Make sure they are in proper working order.

Check if the tractor has multiple PTO engagement modulation settings and has the latest PTO engagement software from the OEM. If unsure, contact your local dealer for tractor capabilities and recommended setting for grain cart operation.

Check the tractor hydraulic oil reservoir and add oil if needed.

Verify that the tractor is adequately ballasted for drawbar operation at the anticipated draft load. See tractor manual for ballasting instructions.

If possible, adjust the tractor drawbar vertically so the topside of the drawbar is approximately 17-22 inches from the ground. Ensure that the drawbar is locked in the center position.

On tractors equipped with a 3-point hitch, raise and secure the linkage to prevent interference with the cart tongue, hydraulic hoses and the hydraulic drive option during turning. It may be necessary to remove tractor 3-point quick attach to avoid damage during turning.

Preparing Cart

Perform the service checks as outlined below. Repair or replace any damaged or worn parts before operating.

Hardware

Check for loose bolts and nuts, and tighten as needed. Check again after the first half-day of operation.

Pivot Pins

Check that all pins are in place and in good condition. Replace any worn, damaged or missing pins.

Hitch

Check hitch wear plates for damage and wear. Be aware of the size of hitch adapter bushing that is being used. Select correct size for the hitch pin/draw bar you are using.

Auger

Inspect auger for damage and wear.

IMPORTANT

- *Remove transport retainer located on auger rest, before folding out upper auger.*



Preparing Cart (continued)

Soft Start System

Check for wear or damage. Lubricate as recommended. Do not over lubricate.

Hydraulic System

Check all hoses and cylinders for signs of leakage. Hoses should not be kinked, twisted or rubbing against sharp edges. Re-route or repair hoses as necessary. Refer to SAFETY section for additional information on safe repair and inspection of hydraulic components.

Tires/Wheels

Check tire pressures and maintain at recommended values listed in the MAINTENANCE section of this manual.



CAUTION

- **IMPROPERLY TORQUED WHEEL NUTS/BOLTS CAN CAUSE A LOSS OF IMPLEMENT CONTROL AND MACHINE DAMAGE. WHEEL NUTS/BOLTS MUST BE CHECKED REGULARLY. SEE TORQUE PAGE IN THE “MAINTENANCE” SECTION FOR PROPER WHEEL NUT/BOLT SPECIFICATIONS. WARRANTY DOES NOT COVER FAILURES CAUSED BY IMPROPERLY TORQUED WHEEL NUTS/BOLTS.**

IMPORTANT

- *Installing wheels without the proper inset could result in hub or spindle failure. This will cause substantial damage to cart.*

For questions regarding new tire warranty, please contact your local original equipment tire dealer. Used tires carry no warranty. Tire manufacturers' phone numbers and web sites are listed in the “MAINTENANCE” section of this manual for your convenience.

Lubrication

Lubricate the cart as outlined in the MAINTENANCE section of this manual.

Hitching to Tractor

Drawbar Connection

This cart is intended to be hitched to a tractor drawbar. Do not attempt to hitch to any other location on the tractor other than the drawbar.

The cart is equipped standard with a single tang hitch. A hitch pin between 1 1/2" or 2" diameter must only be used with a clevis-type tractor drawbar. An optional hammer strap is available if your tractor has a single tang drawbar.

NOTE: The use of a smaller diameter hitch pin will result in additional clearance between the hitch and pin. This additional clearance may cause accelerated pin wear, tractor and cart hitch wear, along with more pronounced jolting from the cart during transport operation.

WARNING

- DO NOT STAND BETWEEN THE MACHINE AND TRACTOR WHEN HITCHING. ALWAYS ENGAGE PARKING BRAKE AND STOP ENGINE BEFORE INSERTING HITCH PIN.

After inserting drawbar pin, secure drawbar pin with a locking device to help prevent uncoupling during use.

Jack Usage

WARNING

- UNHITCHING A LOADED CART CAN CAUSE SERIOUS INJURY OR DEATH DUE TO THE TONGUE RISING OR FALLING. ALWAYS HAVE A LOADED CART ATTACHED TO A TRACTOR. THE JACK IS INTENDED TO SUPPORT AN EMPTY CART ONLY.

IMPORTANT

- Mount jack in storage location indicated after cart is hitched to tractor.

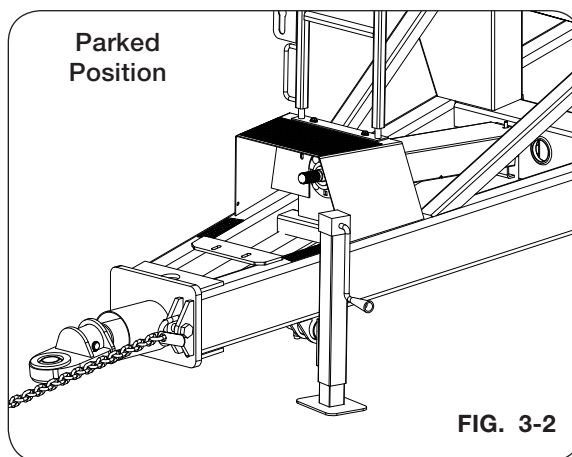

Hitching to Tractor (continued)

Transport Chain Connection

CAUTION

- ALWAYS USE TRANSPORT CHAIN WHEN TRANSPORTING IMPLEMENTS. FAILURE TO USE A TRANSPORT CHAIN COULD CAUSE PERSONAL INJURY IF CART BECOMES DISENGAGED.

Always use intermediate chain support when connecting the grain cart directly to a tractor. DO NOT use the intermediate chain support as the chain attaching point. Fig. 3-3 shows how the transport chain must be installed between the tractor and grain cart.

The chain is rated for towing the grain cart empty on public roads. Never tow a loaded grain cart on public roads. Use only ASABE approved chains. Allow no more slack in the chain than necessary to permit turning.



CAUTION

- REPLACE TRANSPORT CHAIN IF ANY LINK OR END FITTING IS BROKEN, STRETCHED OR DAMAGED. DO NOT WELD TRANSPORT CHAIN.

Hydraulic Connections

IMPORTANT

- When coupling hydraulic hoses to ports on the tractor, be sure that the coupler ends are clean or dust, dirt and debris. Failure to do so could contaminate hydraulic system resulting in excessive wear and possible failure.

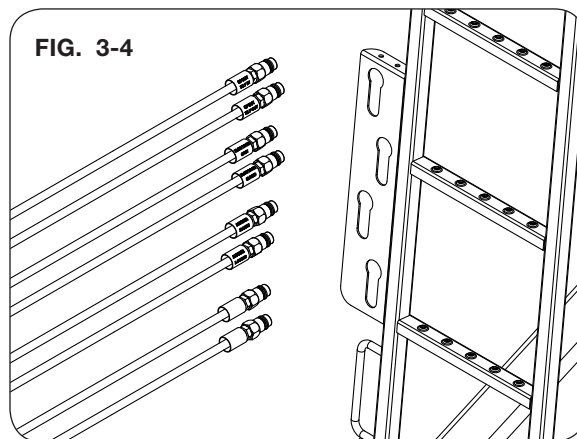

Hitching to Tractor (continued)

Clean hydraulic hose couplers before connecting to the tractor. For convenience, it is recommended to connect the flow door circuit hoses to tractor implement coupler #1, auger spout circuit hoses to coupler #2, and attach auger fold circuit to coupler #3.

This unit is equipped with color bands attached to the hydraulic hoses. This will help in identifying the hose function and correct hook up.

Green: Raise and Lower Auger

Red: Flow Door Open and Close

Yellow: Spout In and Out

White: Spout Tilt In and Out (Optional)

After initial set-up or replacement of any hydraulic component on the cart, air must be removed from the cart's hydraulic system.

Route hoses away from areas that may cause abrasion or kinking of hoses during operation.

Before disconnecting hoses from the tractor, relieve pressure in the system. See the tractor's Operator's Manual for the proper procedure. Shut off engine and apply parking brake before disconnecting hoses. Install couplers into storage slots provided.

Hydraulic Connections for Hydraulic Drive

It is possible that the tractor utilizes more than one pump to achieve higher hydraulic flow rates. To maximize hydraulic flow to auger hydraulic drive motor, refer to tractor's Operator's Manual to determine which couplers should be used to achieve maximum flow. A flow test by your dealer's tractor technician can be performed and is recommended to assure maximum flow without exceeding motor limits.

A case drain hose is supplied with the 100 gpm kit and can be used.

IMPORTANT

- *The case drain line is to be connected to the tractor's low pressure return line ONLY! DO NOT connect to the hydraulic couplers! DO NOT plumb both case drain and hydraulic drive return lines to low pressure return. Pressure in return lines will back flow into case drain and shorten motor life.*

To avoid thermal shock, maintain a temperature difference less than 50 degrees between the tractor's hydraulic fluid and the motor's hydraulic fluid. With the flow door closed, run the motor in very short intervals (bursts with 15 second pauses) or low hydraulic flow rate at startup, in order for hydraulic oil to slowly exchange colder oil in the motor with warmer oil from the tractor. Particularly advised on cold days and/or first loads of the day.

Hitching to Tractor (continued)

Electrical Connections

This cart is equipped with a seven-pin SAE connector plug which will connect with the receptacle found on most newer tractors. If your tractor does not have this type of receptacle, an SAE J-560 seven-point socket can be purchased from your Unverferth dealer (Part number 92824).

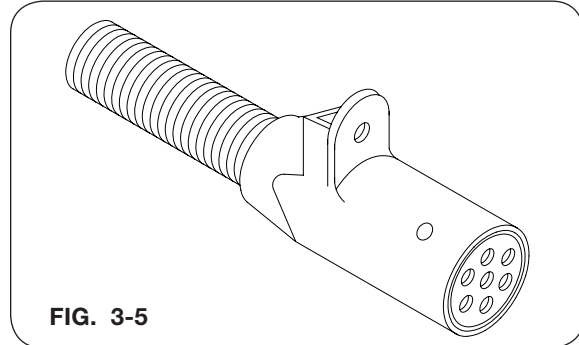

The wiring schematic for this cart, shown in the MAINTENANCE section, complies with AS-ABE Standards. Always verify correct electrical function before using this cart.

Compliance with all lighting and marking laws is the responsibility of the operator at the time of travel.

Please see federal regulation 49 CFR 562; available at www.govinfo.gov for US federal law requirements.

See your Unverferth dealer for additional brackets, reflectors, or lights to meet your requirements.

Towing

This cart is not equipped with brakes. Ensure that the towing vehicle has adequate weight and braking capacity to tow this implement. See towing vehicle's operators manual for towing capacity. Never tow a loaded grain cart over public roads.

Do not exceed 10 mph during off-highway travel. Do not exceed 8 mph when cart is fully loaded.

Secure drawbar pin with a locking device and lock tractor drawbar in centered position. Connect the PTO driveshaft to the tractor.

Secure transport chain to tractor chain support before towing.

CAUTION

- THE STANDARD TRANSPORT CHAIN IS DESIGNED TO SUPPORT AN EMPTY GRAIN CART DURING ROAD TRAVEL.
-

It is probable that this cart is taller, wider and longer than the towing tractor. Become aware of and avoid all obstacles and hazards in the travel path of the equipment, such as power lines, ditches, etc.

Always have the auger folded back into storage position when not in use.

To prevent damage during turning when using non-PTO equipped towing vehicles, store the PTO driveshaft in the brackets provided on the inside right frame rail.

Auger Operation

PTO Driven Auger

DANGER

- **ELECTROCUTION WILL CAUSE SERIOUS INJURY OR DEATH. THE GRAIN CART IS NOT INSULATED. KEEP AWAY FROM ALL ELECTRICAL LINES AND DEVICES. ELECTROCUTION CAN OCCUR WITHOUT DIRECT CONTACT.**
- **ENTANGLEMENT WITH THE DRIVELINE WILL CAUSE SERIOUS INJURY OR DEATH. KEEP ALL GUARDS AND SHIELDS IN GOOD CONDITION AND PROPERLY INSTALLED AT ALL TIMES. AVOID PERSONAL ATTIRE SUCH AS LOOSE FITTING CLOTHING, SHOE STRINGS, DRAWSTRINGS, PANTS CUFFS, LONG HAIR, ETC. THAT CAN BECOME EN-TANGLED IN A ROTATING DRIVELINE.**

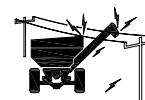

1. Before loading cart or operating auger, verify that the flow control door is closed.
2. Choose an area free from obstructions and unfold auger into unloading position. Allow sufficient time for the cylinder to fully engage the two augers.
3. Engage PTO at low RPM, then increase the PTO RPM to about 1000 RPM.

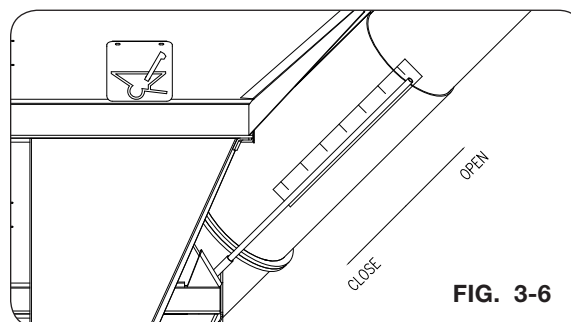

4. Open flow control door to desired unloading rate. Numbers on the auger tube provide a point of reference for operator convenience.

NOTE: If an overload occurs, (Shear-bolt failure or excessive heat/smoke from friction clutch) stop auger immediately. Close flow control door and relieve auger grain pressure by opening bottom door to remove some grain from auger before resuming.

5. To slow or stop grain flow, close flow door, rather than reducing tractor RPM. Close flow door fully when unloading is complete.

NOTE: It is not recommended to disengage auger with flow control door open. Auger system will require substantially more torque to start, placing extra stress on both cart and tractor driveline.

6. Stop PTO. After the PTO has come to a complete stop, fold auger to the transport position.

Optional Equipment

Hydraulic Drive

The optional hydraulically-driven auger permits cart operation using tractors that are not equipped with a PTO. However, due to the power requirements of a grain cart, it should be expected that a hydraulically-driven grain cart will not unload as quickly as a PTO driven cart.

IMPORTANT

- Depending on the option chosen, the motor is rated for either 55 or 100 gpm hydraulic flow at 3000 psi. Sustained flow and pressure above these amounts will dramatically reduce motor life. Be aware of maximum tractor hydraulic flow and pressure before operating auger.

NOTE: A motor containing two pressure and two return lines is a 55 GPM motor. A motor containing three pressure and three return lines is a 100 GPM motor. If unsure of motor size, contact your dealer providing your cart's serial number.

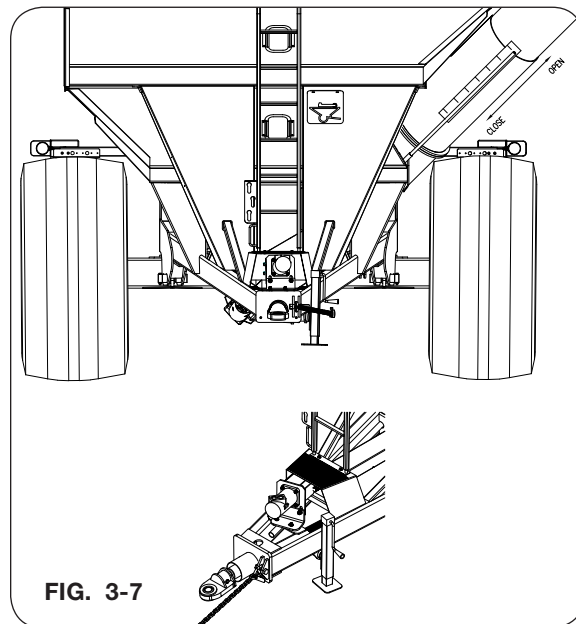

Optional Equipment (continued)

Hydraulic Drive (continued)

NOTE: For complete assembly and operation details for the Hydraulic Drive, please refer to the Hydraulic Drive manual (282894).

1. Before loading cart or operating auger, verify that the flow control door is closed.
2. Choose an area free from obstructions and fully unfold auger to the unloading position.
3. Connect hydraulic hoses to tractor hydraulic circuits. Attach pump pressure hoses to RETRACT ports on tractor.

Multiple connections help utilize the tractor's fully hydraulic power and flow. Use the tractor's flow controls to regulate total output. See hydraulic connections for hydraulic drive in previous "OPERATIONS" sections.

NOTE: The dual connections help utilize full tractor hydraulic power at the cart hydraulic motor. For tractors that have more than 55 GPM available pump output, use tractor flow controls to regulate total output to a maximum of 55 GPM.

4. Engage hydraulic drive circuits at low engine RPM one at a time, then increase engine to full throttle. See hydraulic connections for hydraulic drive in previous "OPERATIONS" sections for cold starts.
5. While watching hydraulic pressure gauge, begin slowly opening flow control door. Stop opening flow control door when pressure (on hydraulic gauge by pump) climbs to within 200 psi less than maximum tractor hydraulic pressure. Ideally, maintaining maximum PTO RPM will optimize unloading performance.

IMPORTANT

- *If auger stalls during unloading, **immediately** place tractor hydraulic controls for motor functions in **FLOAT** to stop auger. Close flow control door, then move all hydraulic controls to **HOLD**. Relieve auger grain pressure by opening auger cleanout door to remove some grain before attempting to restart auger.*
6. To slow or stop grain flow, close flow door rather than reducing tractor RPM. Close flow door fully when unloading is complete.
 7. Stop auger by placing both auger hydraulic circuits in FLOAT. This reduces strain on driveline components and prolongs hydraulic motor life. Move controls to HOLD after auger has come to a complete stop.
 8. Choose an area free from obstructions and fully fold auger to the transport position.

Section IV Maintenance

Lubrication.....	4-2
Gearbox Lubrication	4-3
Seasonal Storage	4-3
Adjusting Cleanout Door	4-4
Auger Driveline.....	4-6
Bearings.....	4-6
Driveline Replacement	4-6
Auger System - Lower Auger Disassembly	4-9
Auger System - Lower Auger Assembly	4-10
Auger System - Upper Auger Disassembly.....	4-12
Auger System - Upper Auger Assembly	4-13
Auger System - Auger Flow Door Cylinder Replacement.....	4-14
Verify Telescoping PTO Shaft Length	4-17
PTO Shaft and Clutch.....	4-19
PTO Quick Disconnect	4-23
Electrical System Schematic.....	4-26
Hydraulic System Schematic.....	4-27
UM520 Auto Unload Manifold Schematic.....	4-28
Wheels and Tires - Wheel Nut Torque	4-29
Wheels and Tires - Tire Pressure.....	4-30
Wheels and Tires - Tire Warranty.....	4-31
Torque Chart - Hardware	4-32
Torque Chart - Hydraulic Fittings.....	4-34

FOR TRACK INFORMATION, PLEASE REFER TO YOUR TRACK MANUAL.

FOR TARP INFORMATION, PLEASE REFER TO YOUR TARP MANUAL.

FOR SCALE INFORMATION, PLEASE REFER TO YOUR SCALE MANUAL.

FOR HYDRAULIC DRIVE INFORMATION, PLEASE REFER TO YOUR HYDRAULIC DRIVE MANUAL.

Lubrication

To keep your grain cart in top operating condition and to assure its proper performance and reliability for a long period of time, periodic inspection and lubrication is a must.

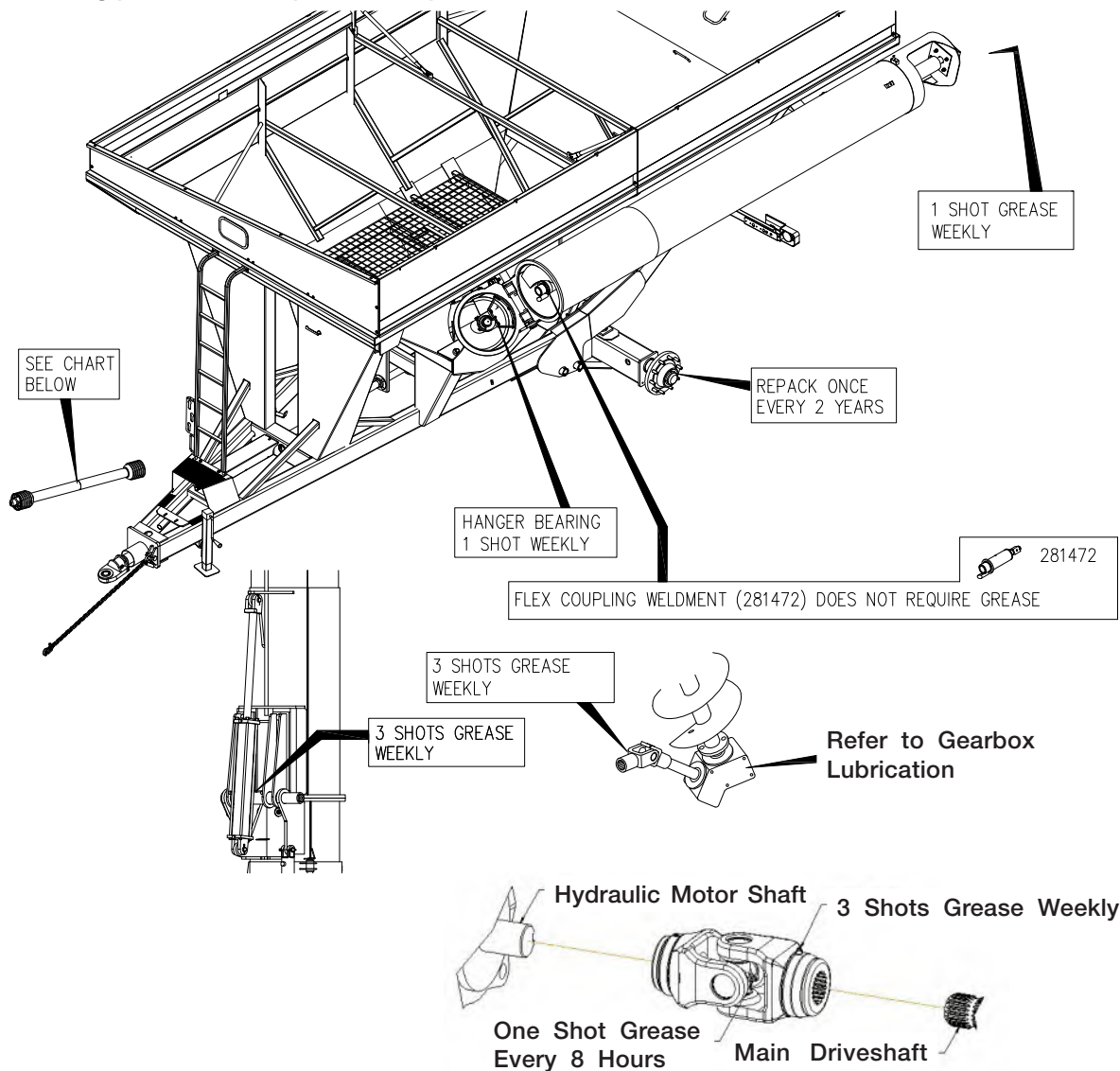

LUBRICATION INSTRUCTIONS FOR DRIVE LINE

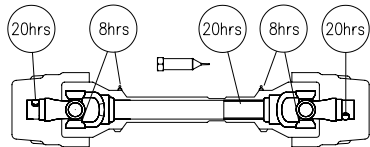

8hrs

20hrs

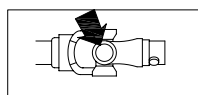

Cross journal

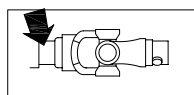

Inner tube

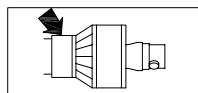

Shield retaining bearing

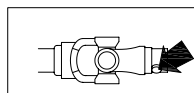

Push-pin set

COAT INNER AND OUTER PROFILES AT BEGINNING AND END OF EACH SEASON

Gearbox Lubrication

Gear box check/fill plug is located on the right hand front side of the housing. To check oil fluid level, place cart on a level surface with the tongue elevated to hitch height and remove the plug. Oil level should be at the bottom thread or approximately 5/8" below the outside gearbox surface.

For Maximum gear box life:
Check oil level every 2 weeks.
Replace oil every season with 32 fl. oz. of 80W90 EP gear lubricant.

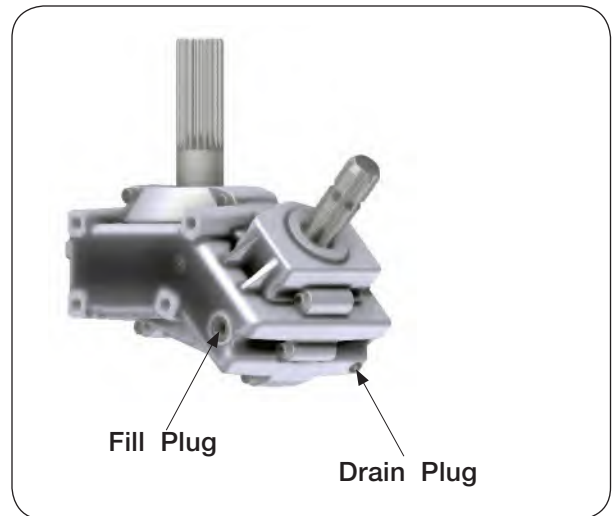

Seasonal Storage

Your cart is an important investment. Spend a little time to protect it from destructive rust and corrosion, You will be repaid in longer service life and better performance.

Do the following before placing the cart in storage:

1. Remove dirt and trash which could cause rusting.
2. Repaint any chipped or scraped areas.
3. Lubricate points as shown on previous page.
4. Inspect for damage or worn parts, replace before next season.
5. Store cart inside, away from livestock.
6. Replace all worn, torn or faded decals and reflectors.
7. Fully open flow door and auger cleanout door to remove any remaining grain and to allow moisture to drain.



Adjusting Cleanout Door

WARNING

- MOVING PARTS CAN CRUSH AND CUT. KEEP AWAY FROM MOVING PARTS.
- KEEP HANDS CLEAR OF PINCH POINT AREAS.
- EYE PROTECTION AND OTHER APPROPRIATE PERSONAL PROTECTIVE EQUIPMENT MUST BE WORN WHILE SERVICING THE IMPLEMENT.

1. Park the empty grain cart on a firm and level surface. Block the tires/tracks on the machine to keep it from moving. Set the tractor's parking brake, shut-off the engine, remove the ignition key and disconnect the PTO shaft.
2. Completely close cleanout door. Inspect and verify that all the grain dust and filings are removed that may prevent the door from shutting completely. (FIG. 4-1)

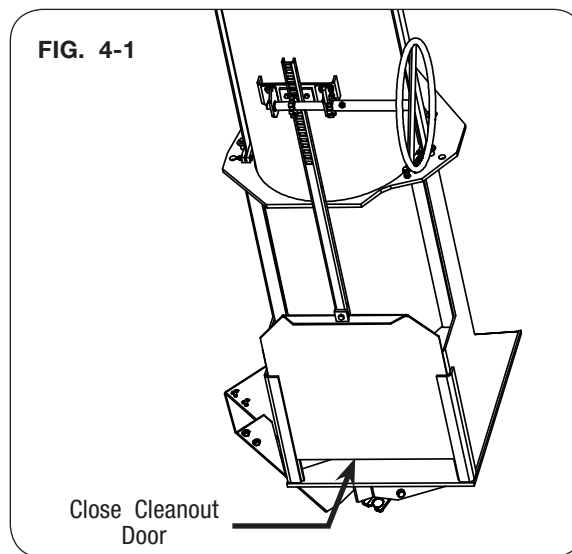

3. Engage the locking plate (268313B). (FIG. 4-2)
4. Loosen mounting hardware. (FIG. 4-2)

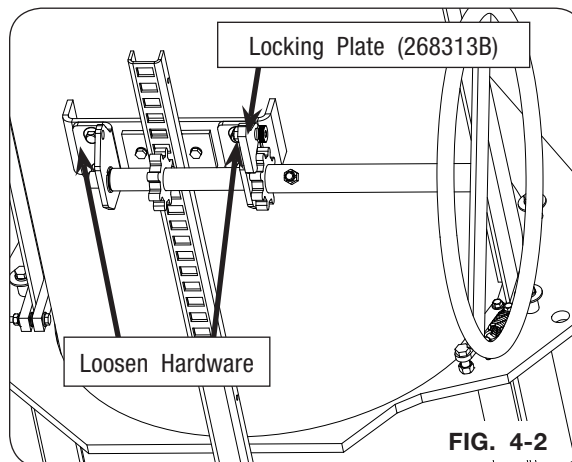

Adjusting Cleanout Door (continued)

5. Push the gear assembly toward bottom of auger to remove excess movement and prevent the door from moving upward when unloading the cart. (FIG. 4-3)

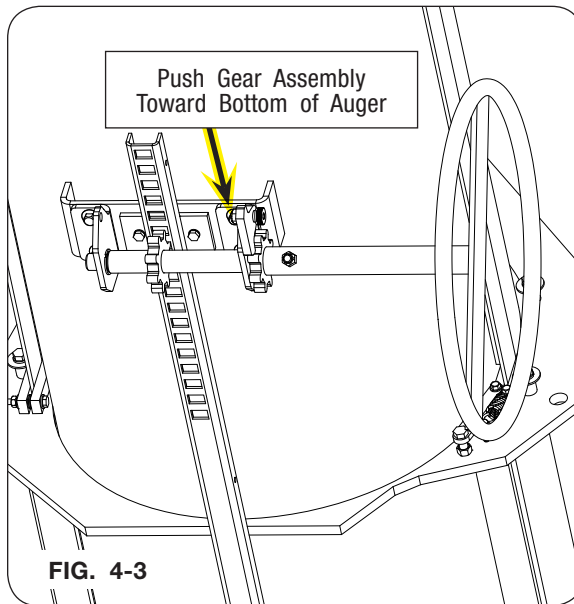

5. Tighten hardware loosened in step 4. (FIG. 4-4)
6. Check door operation. Lock the handle weldment into position. (FIG. 4-4)

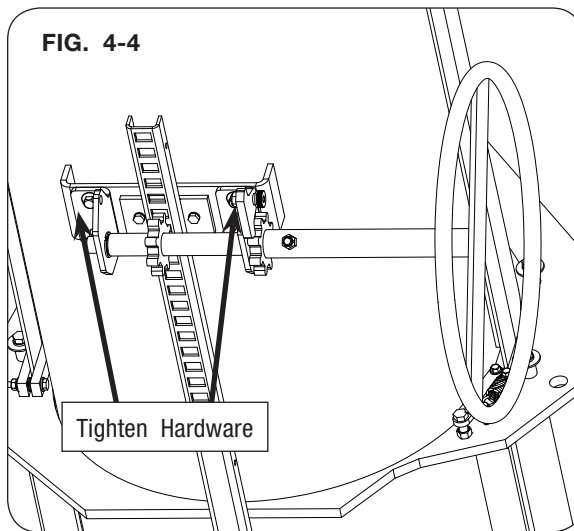

Auger Driveline

Bearings

It is important to periodically check setscrews in all bearings of the driveline for tightness.

Driveline Replacement

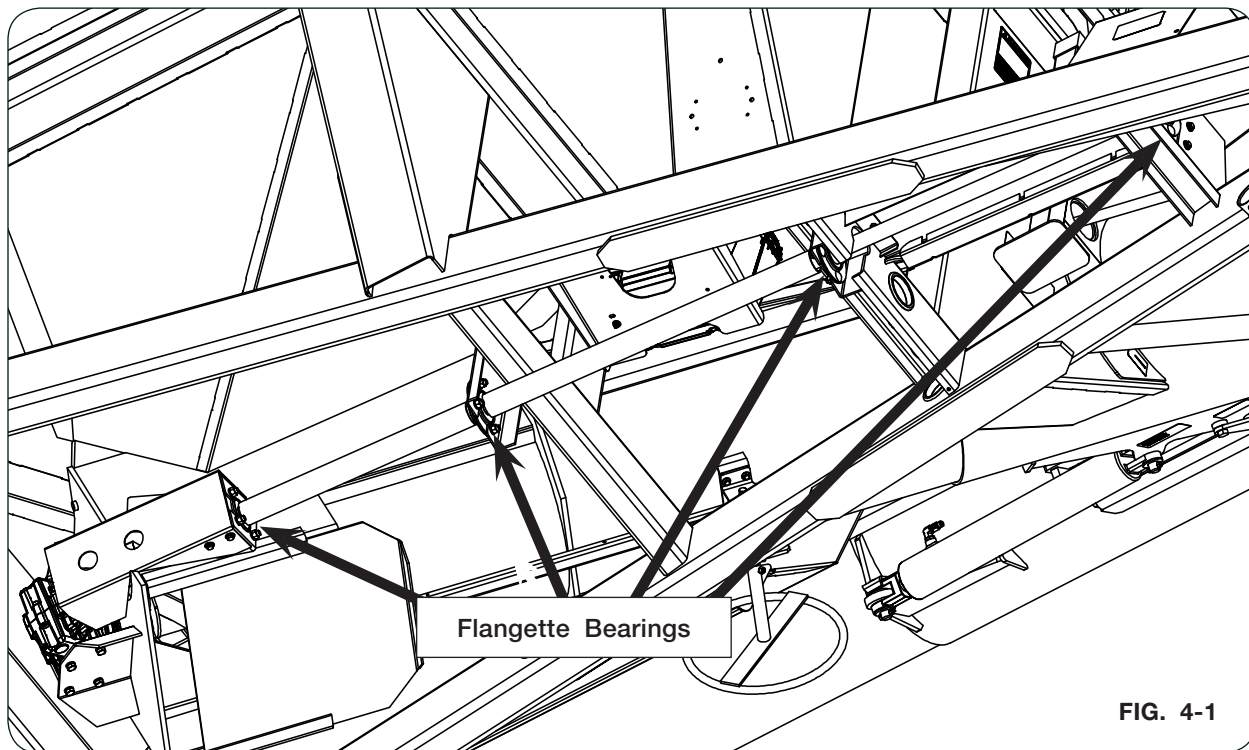

1. Park the empty cart on a firm, level surface. Block the wheels or tracks on the cart to keep it from moving. Set the tractor parking brake, shut off the engine, and remove the ignition key from the tractor before disconnecting driveline assembly and bearing hardware.
2. Loosen the setscrews (9399-071) on all flangette bearings (9003920) (Fig. 4-1).
3. Remove the 1/2" carriage bolts (9388-103), flange nuts (9394-010), and lock washers (9404-025) holding the flangette bearings. Keep hardware. (Fig. 4-2).

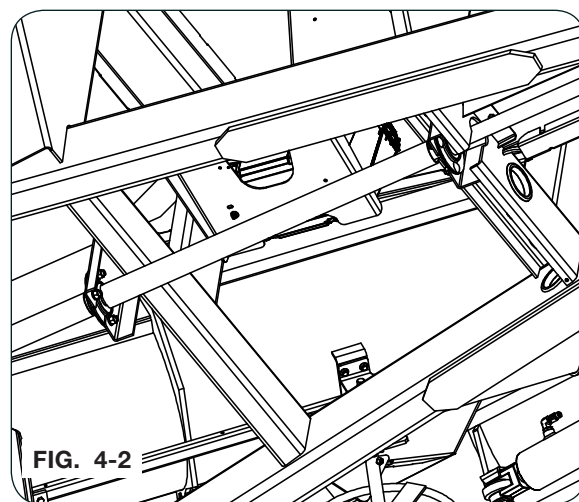

4. Remove paint on driveshaft to allow for easier movement. Slide driveshaft forward until the rear spline is out of the universal joint connected to the gearbox.
5. Drop the gearbox end of driveshaft down and slide driveshaft out of the flangette bearing on the hitch end of the driveshaft.

Auger Driveline (continued)

Driveline Replacement (continued)

6. Remove bearings, bearing mounts, universal joint cover, PVC driveshaft covers, and driveline cover, located behind the ladder, off the current driveshaft.
7. When installing new bearings (9003920) onto new driveshaft (9007718), assemble new 25" PVC driveshaft cover (291555) between bearings near the gearbox, and new 36" PVC driveshaft cover (291554) between bearings behind the hitch driveline cover. (FIG. 4-3)

NOTE: Ends of driveshaft are symmetrical.

8. Slide the hitch end of the driveshaft, bearing and hitch driveline cover into the bearing near hitch of the cart. (FIG. 4-3)
9. Raise the gearbox end of the driveshaft up and insert the original 1/2" carriage bolts, flange nuts, and lock washers into the mounting flanges making sure that the bearing flanges are both on the front side of the mounting brackets. Only loosely tighten the hardware.
10. Slide driveshaft down into the universal joint attached to the gearbox until the end of the shaft extends into the universal joint about 2 3/8". Ensure universal joint and driveshaft splines completely engage. Verify the hitch end for adequate length for driveline assembly to connect. (FIG. 4-4)

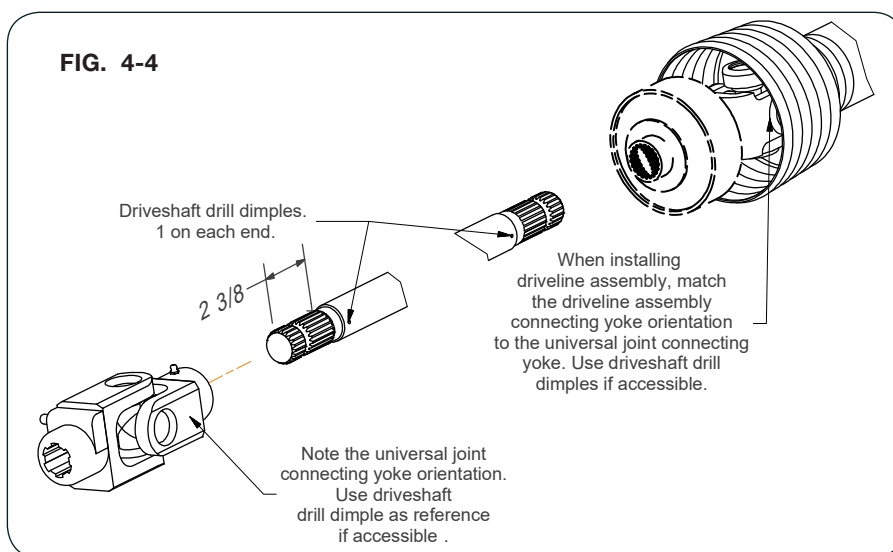
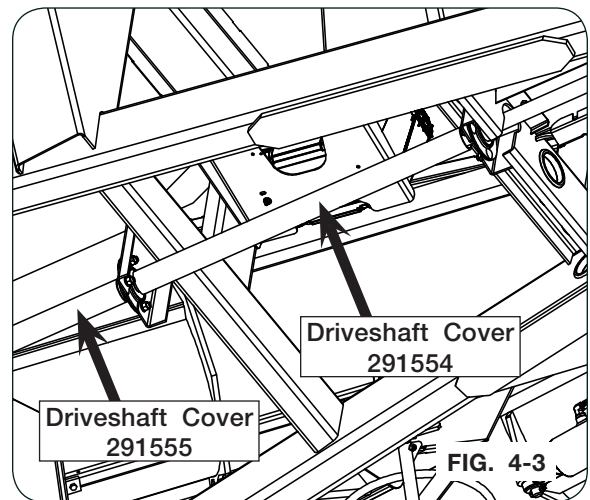

Auger Driveline (continued)

Driveline Replacement (continued)

11. Tighten all flange mounting hardware.
12. With bearing mounting hardware loosely tightened, drill a setscrew dimple in the driveshaft by going through the bearing setscrew threaded hole to dimple the driveshaft being careful to not damage threads. Drill the dimple to a depth that setscrews are flush with the bearing prior to applying thread locker and installing setscrews. (FIG. 4-5)
13. For alignment of the yoke, the orientation of the universal joint at the gearbox must be in line with the driveshaft drill dimple when the driveline assembly is attached. (FIG. 4-5, 4-6, and 4-7)

NOTE: Grease gearbox and universal joint before installing universal joint cover.

14. Attach new universal joint cover (290720B) to the bearing mount in front of the gearbox using original 3/8"-16UNC capscrews and 5/16"-18UNC weld nuts. Review to ensure PVC driveshaft covers and driveline cover, located behind the ladder, are in place and hardware tightened prior to operation.
15. Apply thread lock on bearing setscrews and tighten.
16. Test run driveline. Check for noise and/or vibration and address immediately.

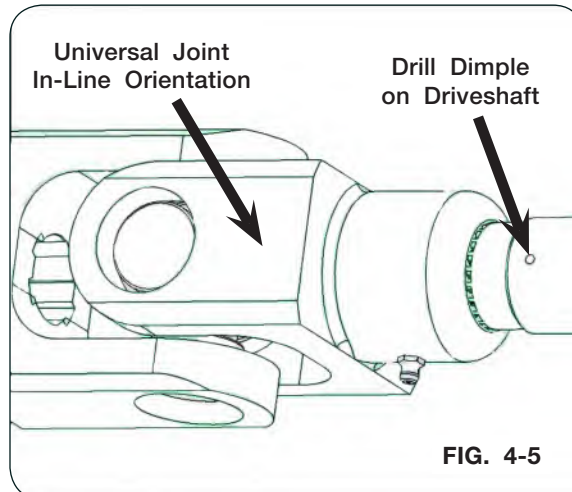

FIG. 4-5

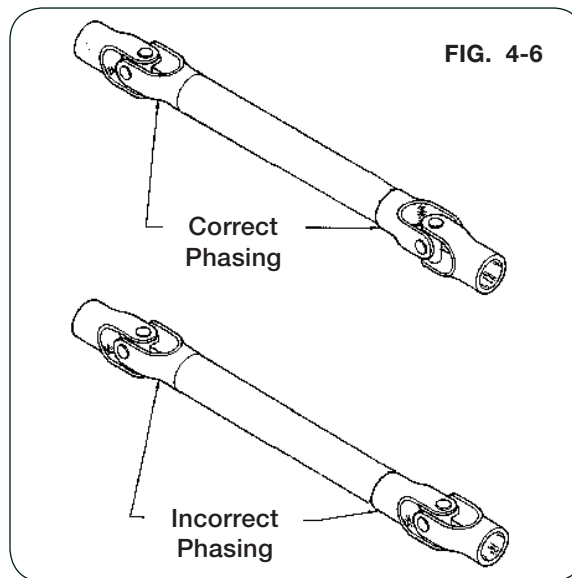

FIG. 4-6

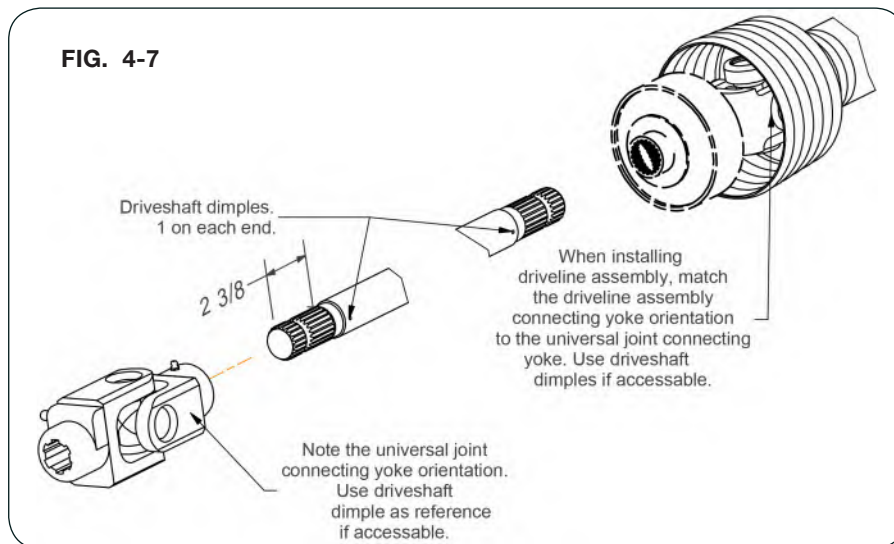

FIG. 4-7

Auger System

WARNING

- TO PREVENT PERSONAL INJURY OR DEATH, ALWAYS ENSURE THAT THERE ARE PEOPLE WHO REMAIN OUTSIDE THE CART TO ASSIST THE PERSON WORKING INSIDE, AND THAT ALL SAFE WORKPLACE PRACTICES ARE FOLLOWED. THERE IS RESTRICTED MOBILITY AND LIMITED EXIT PATHS WHEN WORKING INSIDE THE IMPLEMENT.
- KEEP HANDS CLEAR OF PINCH POINT AREAS.
- EYE PROTECTION AND OTHER APPROPRIATE PERSONAL PROTECTIVE EQUIPMENT MUST BE WORN WHILE SERVICING IMPLEMENT.
- FALLING OBJECTS CAN CAUSE SERIOUS INJURY OR DEATH. DO NOT WORK UNDER THE MACHINE AT ANY TIME WHILE BEING HOISTED. BE SURE ALL LIFTING DEVICES AND SUPPORTS ARE RATED FOR THE LOADS BEING HOISTED. THESE ASSEMBLY INSTRUCTIONS WILL REQUIRE SAFE LIFTING DEVICES UP TO 4,000 LBS. SPECIFIC LOAD RATINGS FOR INDIVIDUAL LOADS WILL BE GIVEN AT THE APPROPRIATE TIME IN THE INSTRUCTIONS.
- MOVING OR ROTATING COMPONENTS CAN CAUSE SERIOUS INJURY OR DEATH. ALWAYS DISCONNECT POWER SOURCE BEFORE SERVICING. ENSURE SERVICE COVERS, CHAIN/BELT COVERS AND CLEAN-OUT DOOR(S) ARE IN PLACE AND SECURELY FASTENED BEFORE OPERATING MACHINE.



Lower Auger Disassembly

1. Remove the three 3/8"-16UNC x 1 1/4" cap-screws (9390-056), six flat washers 3/8" (9405-076), three lock washers 3/8" (9404-021) and hex nuts 3/8"-16UNC (9394-006) which secures the hanger bearing weldment (281502B) to the auger tube (Fig. 4-1).
2. Using a safe lifting device rated for a minimum of 700 lbs., remove auger from auger tube and perform required repair or replacement.
3. Remove the two 5/8"-11UNC x 6" cap-screws (9390-136), lock washers 5/8" (9404-029) and hex nuts 5/8"-11UNC (9394-014) which secures the drive dog to the auger as shown in Fig. 18.

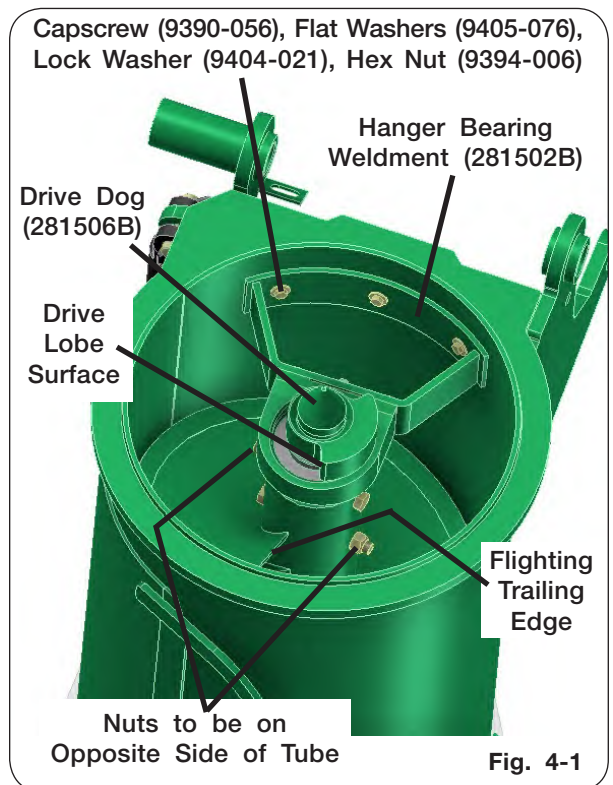

Fig. 4-1

Auger System (continued)

Lower Auger Assembly

1. When installing the coupler into the auger pipe, the lower auger flighting should be set with the driving surface of the drive lobe at a 11:00 position and the flighting edge at a 12:00 position when looking from the top down towards the gearbox, see figure 4-2. The upper auger flighting should be set with the drive pin at a 9:00 position and the end flighting will be at an approximate 12:00 position when looking into the upper auger, see figure 4-3.

Lower Auger: Assemble the drive dog weldment (281506B) and hanger bearing weldment (281502B) to the auger making sure the drive dog weldment contact surface (for upper auger pin) is located approximately 30 degrees behind the lower auger flighting trailing edge. Secure with two 5/8"-11UNC x 6" capscrews (9390-136), lock washers (9404-029) and hex nuts 5/8"-11UNC (9394-014), installed opposite of each other, as shown in Fig. 4-1.

NOTE: Position of the drive dog weldment maintains correct timing and efficiencies of the upper and lower auger flightings.

2. Using a safe lifting device rated for a minimum of 700 lbs., install the lower auger sub-assembly into the lower auger housing. Align auger end with the three pin drive bushing and securely engage together. Secure hanger bearing to housing wall with three 3/8"-16UNC x 1 1/4" capscrews (9390-056), six flat washers (9405-076), three lock washers (9404-021) and hex nuts 3/8"-16UNC (9394-006) (Fig. 4-1).
3. Once secure, tighten hanger bearing weldment hardware.

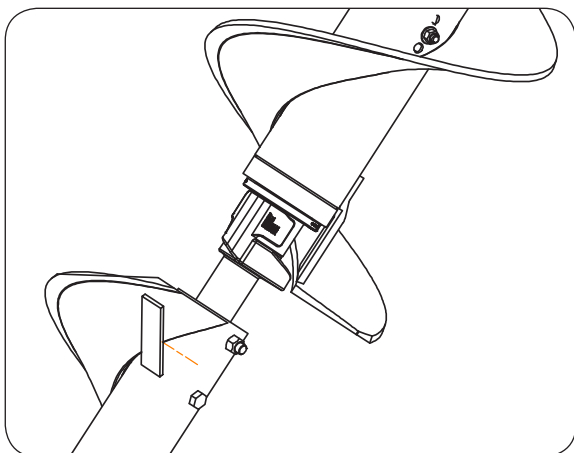

Upper Auger

Fig. 4-3

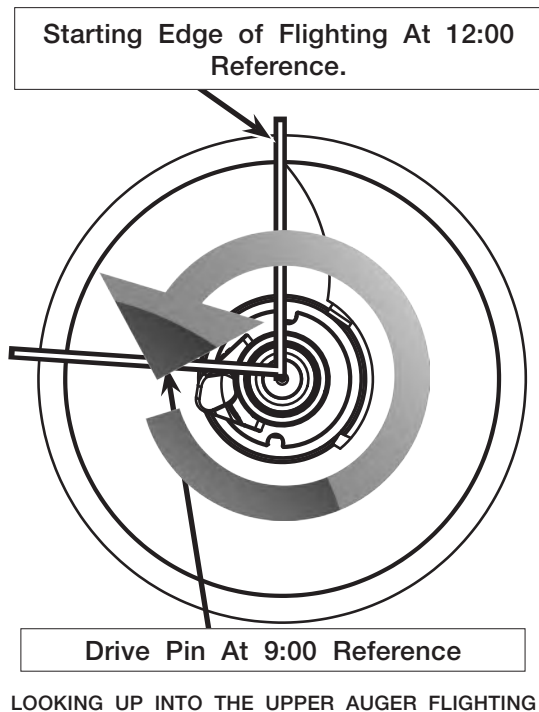

Drive Lobe Driving Edge At 11:00 Reference

Fig. 4-2

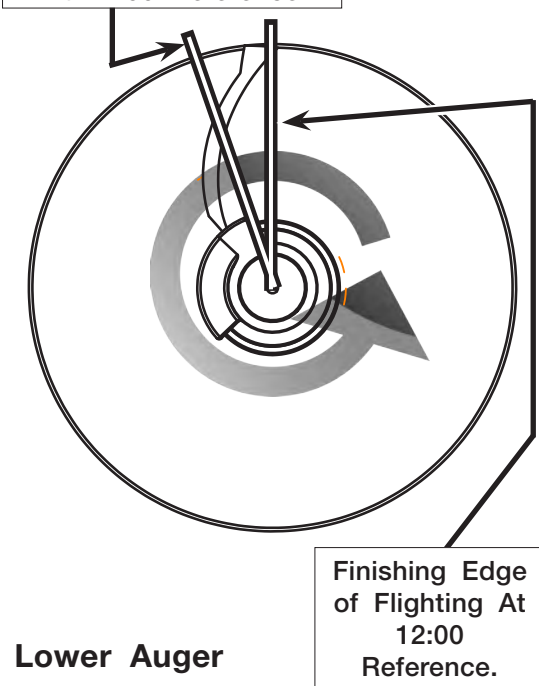

Auger System (continued)

Lower Auger Assembly (continued)

4. **5-Pin Drive Bushing Weldment:**
 Rotate auger 360 degrees to ensure it is centered on the drive bushing weldment (286436) and the five pins are engaged with auger end. Check for flighting interference or binding along housing and at lower end. A portion of flighting may need to be removed from lower end of auger to ensure operational clearances. (Fig. 4-4 & Fig. 4-5)

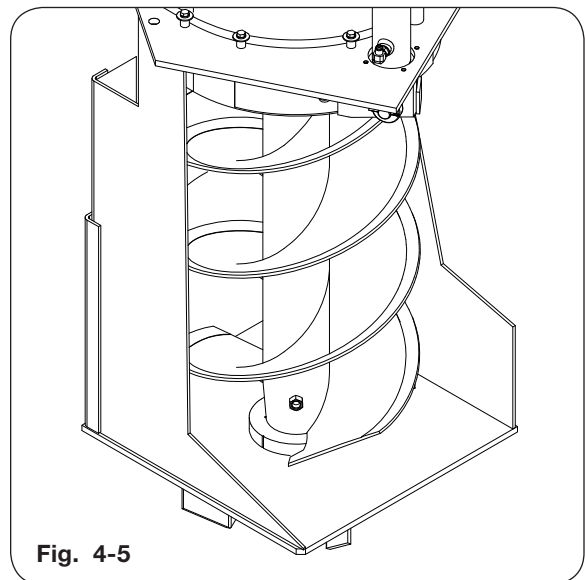
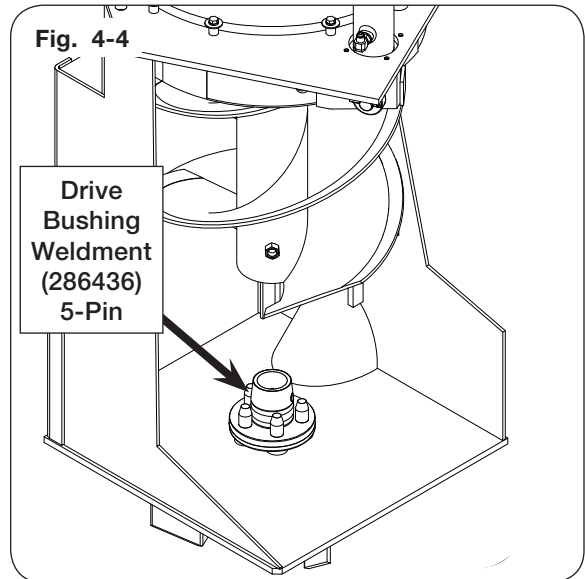

5. Raise the upper auger into position, checking upper drive dog engagement with lower auger drive dog.
6. Lower the upper auger. Lubricate the pillow block bearing (9004731) (Fig. 4-6). Check and remove any loose parts in the auger tube interior prior to start-up.

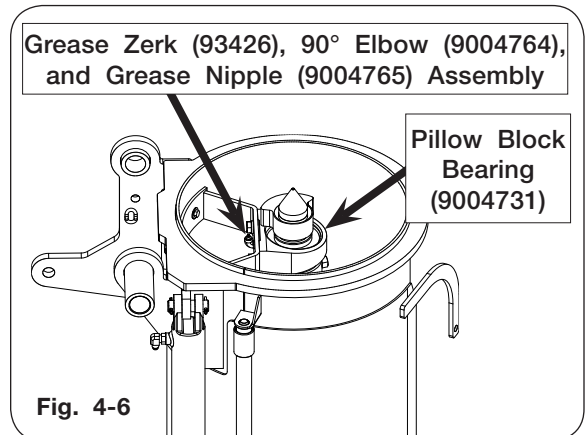

Auger System (continued)

Upper Auger Disassembly

1. Support the upper auger assembly using a 2-ton hoist and two straps rated for 2000 lbs.
2. Remove auger tube cylinder pin and carefully swing cylinder down without breaking hose connections.
3. Disconnect auger and chute light.
4. Remove chute assembly.
5. Remove auger indicator cable from the bolt on bracket. With auger tube fully supported, remove the 7/8"-9UNC x 2" capscrews (9390-164) and flat washers (97041) from the upper auger pivot bracket.
6. Lift upper auger assembly from unit. Repair or replace as required.
7. To remove auger from tube, loosen two bearing setscrews and remove 5/16" x 2" machine screw retainer.
8. Inspect upper auger bearing, springs and four 1/2" x 5 1/2" capscrews and locknuts. Replace if necessary.

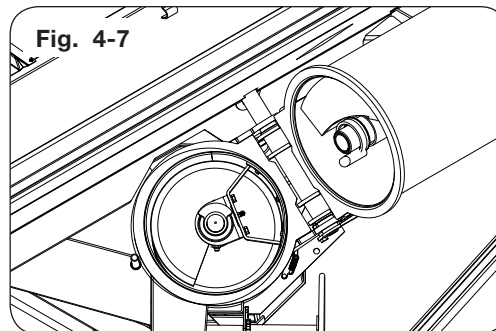

Auger System (continued)

Upper Auger Assembly

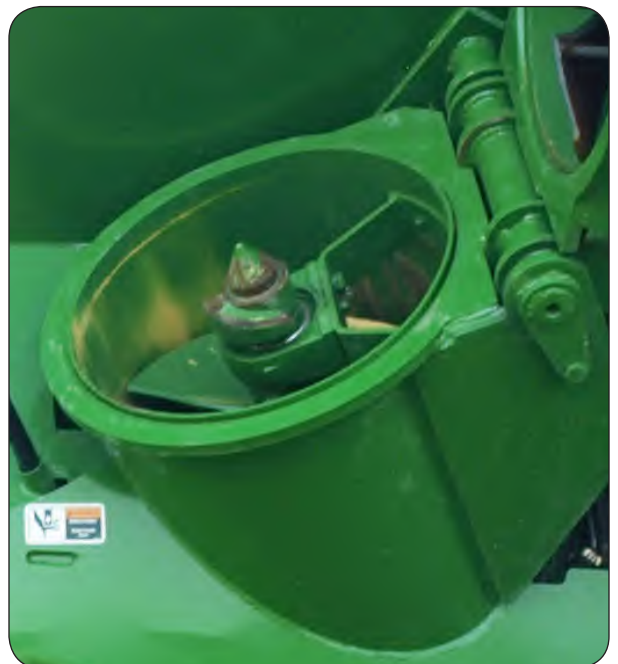
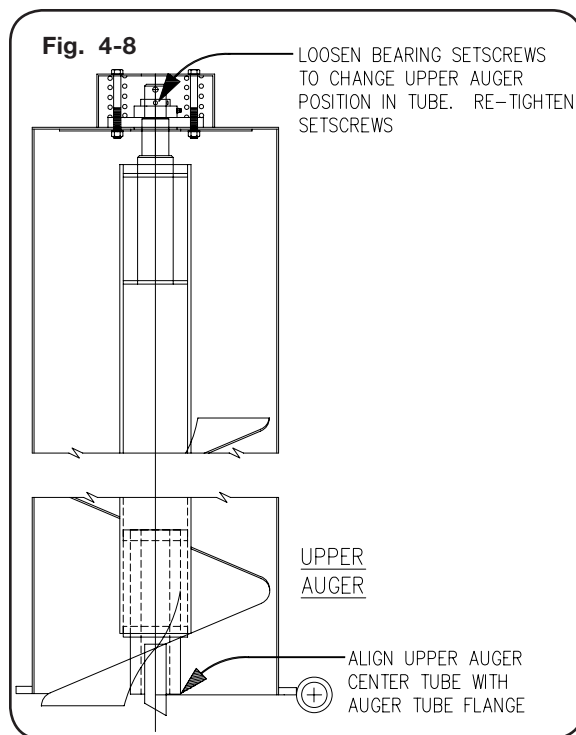

1. Install upper bearing and spring assembly if previously removed.
2. Insert auger in auger tube. Back out bearing setscrews and insert auger stub shaft through bearing. Retain auger with 5/16" x 2" machine screw and nut.
3. Position opposite auger end flush with auger tube flange and tighten bearing setscrews and 5/16" x 2" machine screw
4. Lift upper auger assembly into position using and adequate hoist and slings with a minimum capacity of 600 lbs. to support the upper auger. Install pivot pin. Align retainer holes and install bolt and nut.
5. Install chute assembly.
6. Reattach indicator cable.
7. Connect auger and chute light.
8. Reinstall hydraulic cylinder and pivot pins. Clamp hoses into position and recheck connector tightness.



Auger System (continued)

Auger Flow Door Cylinder Replacement

WARNING

- TO PREVENT PERSONAL INJURY OR DEATH ALWAYS ENSURE THAT THERE ARE PEOPLE WHO REMAIN OUTSIDE THE CART TO ASSIST THE PERSON WORKING INSIDE, AND THAT ALL SAFE WORKPLACE PRACTICES ARE FOLLOWED. THERE IS RESTRICTED MOBILITY AND LIMITED EXIT PATHS WHEN WORKING INSIDE THE IMPLEMENT.
- NEVER ENTER CART WITH AUGER OR TRACTOR RUNNING. SERIOUS OR FATAL INJURY CAN OCCUR DUE TO ENTANGLEMENT WITH ROTATING COMPONENTS. ALWAYS STOP ENGINE AND REMOVE KEY BEFORE ENTERING CART.
- EYE PROTECTION AND OTHER APPROPRIATE PERSONAL PROTECTIVE EQUIPMENT MUST BE WORN WHILE SERVICING IMPLEMENT.
- KEEP HANDS CLEAR OF PINCH POINT AREAS. 
- RELIEVE HYDRAULIC SYSTEM OF ALL PRESSURE BEFORE ADJUSTING OR SERVICING. SEE TRACTOR OPERATOR'S MANUAL FOR PROPER PROCEDURES.
- HIGH-PRESSURE FLUIDS CAN PENETRATE THE SKIN AND CAUSE SERIOUS INJURY OR DEATH. USE CARDBOARD OR WOOD TO DETECT LEAKS IN THE HYDRAULIC SYSTEM. SEEK MEDICAL TREATMENT IMMEDIATELY IF INJURED BY HIGH-PRESSURE FLUIDS. 
- HYDRAULIC SYSTEM MUST BE PURGED OF AIR BEFORE OPERATING TO PREVENT SERIOUS INJURY OR DEATH.

1. Park the empty grain cart on a firm, level surface and extend auger. Block the tires/tracks on the machine to keep it from moving. Unfold upper auger to make the flow door cylinder easier to access. If possible, close the flow door at least 8" from the fully open position. Relieve hydraulic pressure, see tractor operator's manual. Set the tractor's parking brake, shut-off the engine, remove the ignition key and disconnect the PTO shaft.



Auger System (continued)

Auger Flow Door Cylinder Replacement (continued)

2. On the inside of the cart, open the screen service access panel shown in Fig. 4-9.

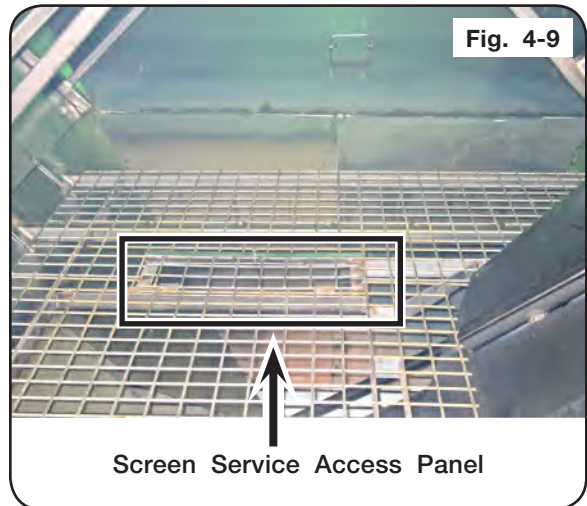

3. Remove the cotter pins from the lower cylinder pin then remove the pin. Then remove the four 3/8"16UNC x 1" flange bolts holding on the gasket and gasket plate, shown in Fig. 4-10.



4. Remove all tools and extra hardware from the grain cart. Make sure all personnel are outside of the hopper. Then, retract the cylinder so that there is about 8" of clearance between the cylinder clevis and the lug.
5. Relieve hydraulic pressure, shut off the engine, remove the ignition key, and disconnect the hydraulic hoses from the tractor and cart.

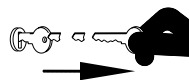

Auger System (continued)

Auger Flow Door Cylinder Replacement (continued)

6. Label the hydraulic hoses to indicate upper and lower. Disconnect them from the cylinder, along with the lower hydraulic fitting (Fig. 4-11).

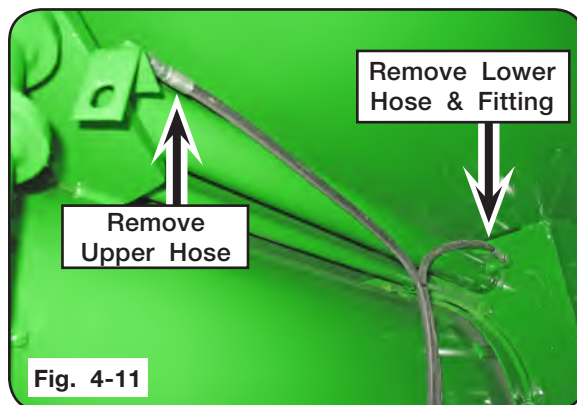

7. Remove the cotter pins from the upper cylinder pin and remove pin (Fig. 4-12).



8. Slide the flow door cylinder through the hole in the junction box until the upper cylinder clevis clears the lug, then raise the top of the cylinder above the auger fold bushing and remove the cylinder.
9. Replace with the new cylinder and insert the upper cylinder pin. Remove the cylinder port plugs. Manually extend the cylinder until the lower clevis lines up with the door lug and assemble the pin and cotter pins. Assemble hydraulic fittings and attach hoses.
10. Replace rubber gasket and gasket plate with 3/8"-16UNC x 1" flange screws, shut and secure the screen service access panel.
11. Remove all tools and extra hardware from the grain cart. Make sure all personnel are outside of the hopper. **After the hydraulic components have been tightened, purge air from system as follows:**
 - A. Pressurize the system and maintain system at full pressure for at least 5 seconds after cylinder rods stop moving. Check that all cylinders have fully extended or retracted.
 - B. Check oil reservoir in hydraulic power source and re-fill as needed.
 - C. Pressurize system again to reverse the motion of step A. Maintain pressure on system for at least 5 seconds after cylinder rods stop moving. Check that cylinders have fully extended or retracted.
 - D. Check for hydraulic leaks using cardboard or wood. Tighten connections according to directions in the Torque Specifications in your Operator's Manual.
 - E. Repeat steps A, B, C and D three or four times.

Verify Telescoping PTO Shaft Length

⚠ WARNING

- PROPERLY EXTENDED AND COLLAPSED LENGTHS OF THE TELESCOPING PTO SHAFT MUST BE VERIFIED BEFORE FIRST OPERATION WITH EACH AND EVERY DIFFERENT TRACTOR. IF THE EXTENDED LENGTH OF THE PTO SHAFT IS NOT SUFFICIENT, IT MAY BECOME UNCOUPLED IN OPERATION AND CAUSE SERIOUS INJURY OR DEATH FROM CONTACT WITH UNCONTROLLED FLAILING OF PTO SHAFT ASSEMBLY COMPONENTS.

An excessive collapsed length can result in damage to the PTO driveline and attached components. This is most likely to occur during extreme turning angles and/or travel over rough terrain. Conditions are amplified on tractors with tracks operating in uneven terrain, particularly rice levies. Damaged driveline components can result in unsafe operation and severely reduced driveline component life.

NOTE: Do not exceed 10 degrees beyond a straight pull line while operating the PTO.

To verify proper extended and collapsed lengths, use the following procedure:

1. Fully collapse PTO shaft and measure length "L" (Fig. 4-13).

Enter here: _____(1) (Verify that outer tube does not bottom out on surrounding plastic shield components).

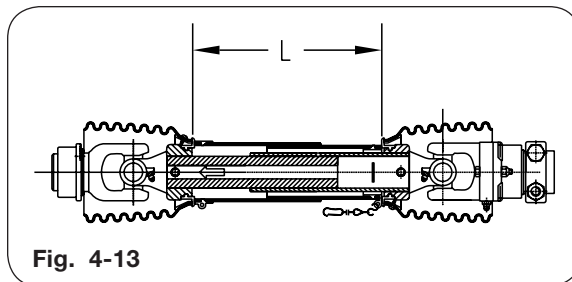

2. Pull apart PTO telescoping shaft ends and measure lengths "T" & "C" (Fig. 4-14).

Add "T" & "C" measurements together
Enter total here: _____(2)

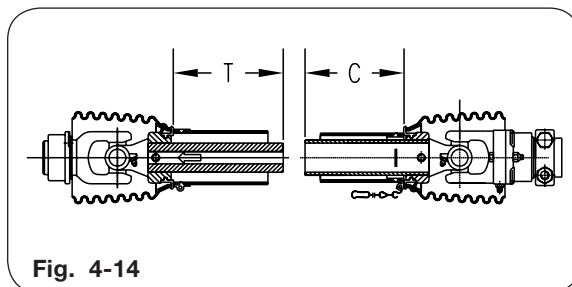

3. Calculate maximum recommended extended length:
 - a. Subtract line 1 from line 2. Enter here: _____(a)
 - b. Divide line (a) by 2. Enter here: _____(b)
 - c. Add line (b) to line 1. Enter here: _____(c)
 - d. Subtract 3 inches from line (c). Enter here: _____(d)

This is the maximum recommended extended length (LB).

Verify Telescoping PTO Shaft Length (continued)

4. Hitch tractor drawbar to cart, ensuring that tractor and cart are on level ground and coupled as straight as practical.
5. Connect PTO shaft to tractor, and measure length “L” from same points as used in step 1. **Ensure that this measurement does not exceed the maximum recommended extended length calculated in step 3 above.** If necessary, choose a shorter drawbar position, or obtain a longer PTO shaft assembly before operating cart.
6. Position the tractor to obtain tightest turning angle, relative to the cart.

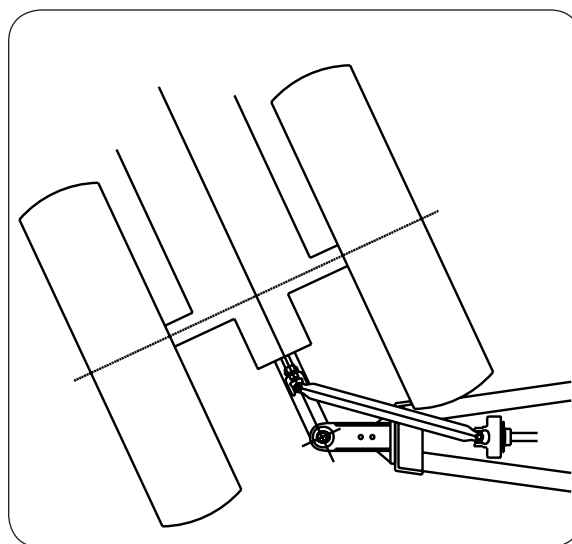

7. Measure length “L” from same points as used in step 1. This distance must be at least 1.5 inches greater than the distance measured in step 1. If necessary, adjust length of PTO shaft by cutting inner and outer plastic guard tubes and inner and outer sliding profiles by the same length. Round off all sharp edges and remove burrs before greasing and reassembling shaft halves.

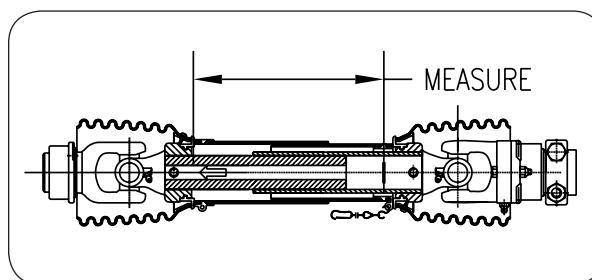

PTO Shaft and Clutch

Lubrication (Figs. D1 - D6)

Lubricate with quality grease before starting work and every 8 operating hours. Clean and grease PTO driveshaft before each prolonged period of non-use. Molded nipples on the shield near each shield bearing are intended as grease fittings and should be lubricated every 8 hours of operation! Telescoping members must have lubrication to operate successfully regardless of whether a grease fitting is provided for that purpose! Telescoping members without fittings should be pulled apart and grease should be added manually. Check and grease the guard tubes in winter to prevent freezing.

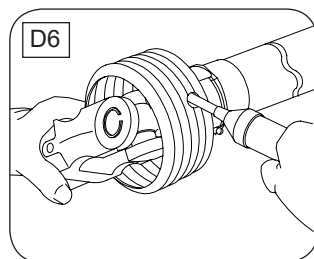
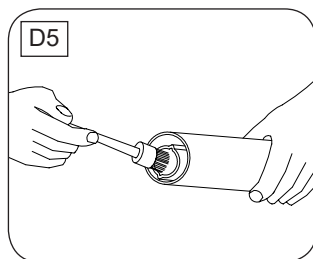
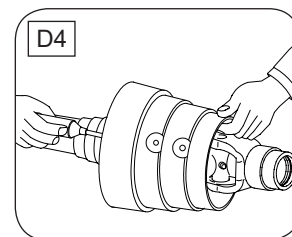
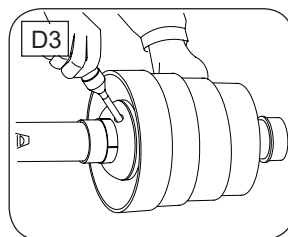
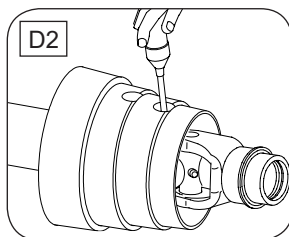
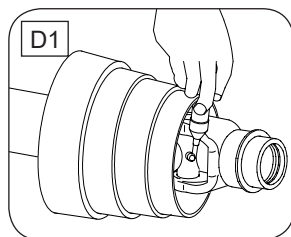
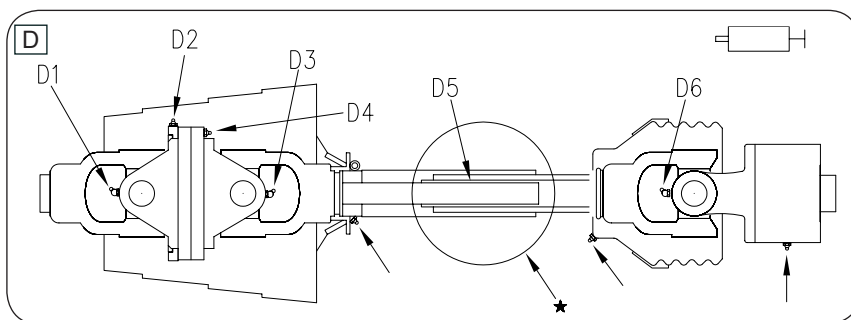

PTO Shaft and Clutch (continued)

Coupling the PTO Driveshaft (Figs. E1 - E2)

Clean and grease the PTO and implement input connection (IIC)

AS-Lock

1. Pull locking collar and simultaneously push PTO driveshaft onto PTO shaft until the locking device engages.

Push-Pull Lock

2. Pull locking collar and simultaneously push PTO driveshaft onto PTO shaft until the locking device engages.

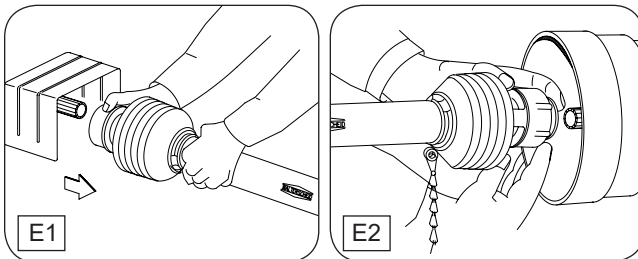

⚠ WARNING

- CHECK TO INSURE ALL THE LOCKS ARE SECURELY ENGAGED BEFORE STARTING WORK WITH THE PTO DRIVESHAFT.

Length Adjustment (Figs. F1 - F4)

NOTE: Maximum operating length LB. (Refer to “Verify Telescoping PTO Shaft Length” for LB length.)

1. To adjust length, hold the half-shafts next to each other in the shortest working position and mark them.
2. Shorten inner and outer guard tubes equally.
3. Shorten inner and outer sliding profiles by the same length as the guard tubes.
4. Round off all sharp edges and remove burrs. Grease sliding profiles.

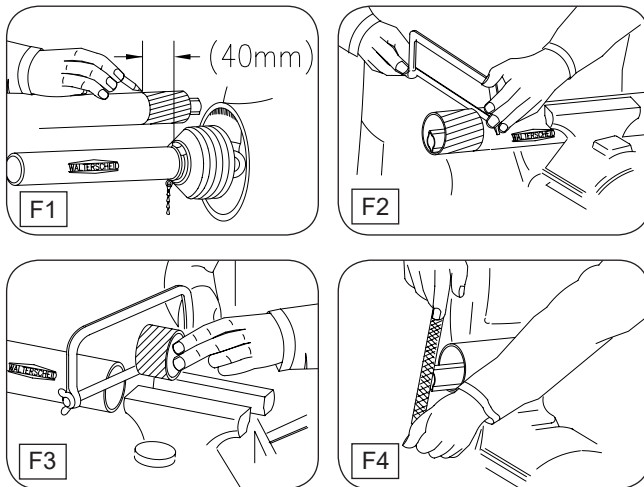

⚠ WARNING

- CHECK THE LENGTH OF THE TELESCOPING MEMBERS TO INSURE THE DRIVELINE WILL NOT BOTTOM OUT OR SEPARATE WHEN TURNING AND/OR GOING OVER ROUGH TERRAIN.

PTO Shaft and Clutch (continued)

Chains (Figs. G1 - G3)

NOTE: The chain is intended to prevent the shield from rotating against non-moving parts and thereby preventing shield damage. A properly installed chain will increase the service life of the shield.

1. Chains must be fitted so as to allow sufficient articulation of the shaft in all working positions. Care must be taken to be sure that chain does not become entangled with drawbar hitch or other restrictions during operation or transport of machine.
2. The PTO driveshaft must not be suspended from the chain.

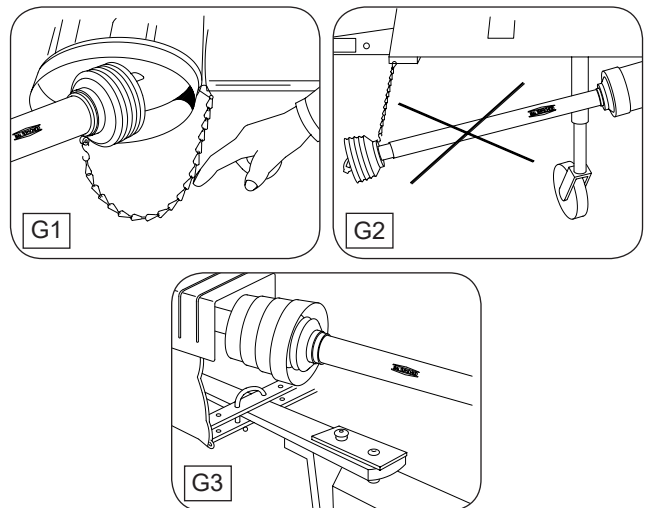

Shear Bolt and Friction Clutches (Figs. H1 - H2)

1. Shear bolt clutches:

When the torque is exceeded, power flow is interrupted due to the bolt shearing. The torque is re-established by replacing the broken shear bolt. Use only the bolt specified in the Operator's Manual for replacement. Remove locking screw.

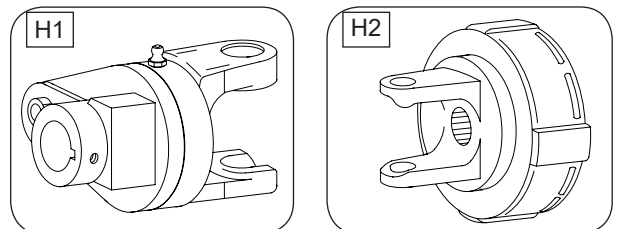

Friction clutches:

When overload occurs, the torque is limited and transmitted constantly during the period of slipping. Short-duration torque peaks are limited.

Prior to first utilization and after long periods out of use, check working of disk clutch.

- a. Tighten nuts until friction disks are released. Rotate clutch fully.
- b. Turn nuts fully back. Now the clutch is ready for use. Fig. H3 shown.

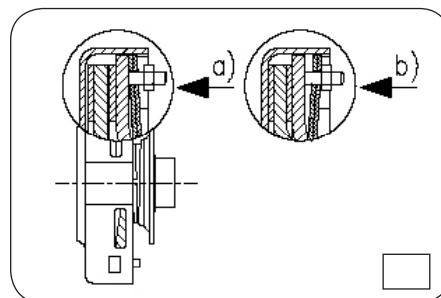

IMPORTANT

- Avoid extended and frequent slippage of overload clutches.

PTO Shaft and Clutch (continued)

To Dismantle Guard (Figs. J1 - J4)

1. Remove locking screw.
2. Align bearing tabs with cone pockets.
3. Remove half-guard.
4. Remove bearing ring.

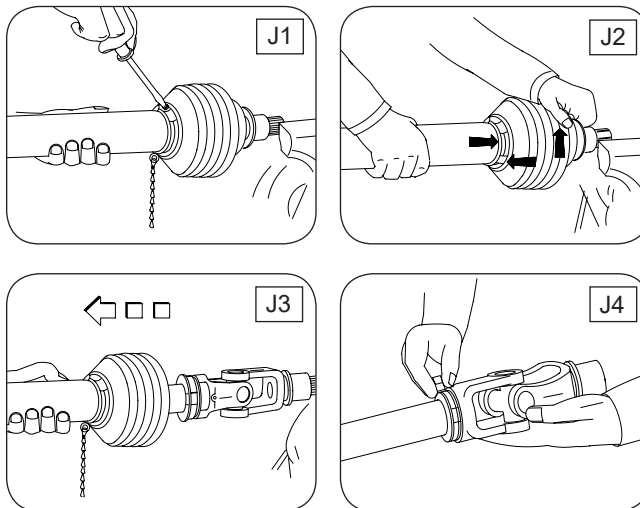

To Assemble Guard (Figs. K1 - K5)

1. Grease yoke groove and inner profile tube.
2. Fit bearing ring in groove with recesses facing profile tube.
3. Slip on half-guard.
4. Turn cone until it engages correctly.
5. Install locking screw.

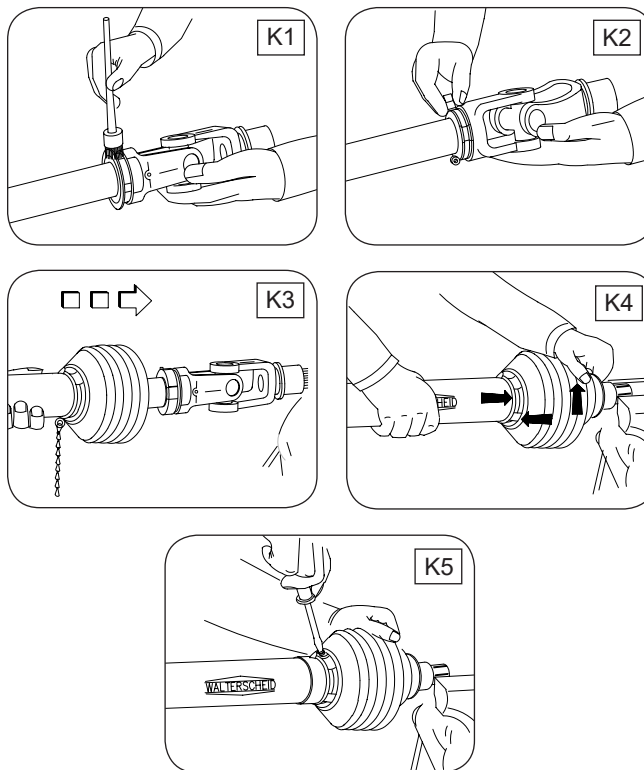

PTO Shaft and Clutch (continued)

To Assemble Cone (Figs. L1 - L3)

1. Dismantle guard (Figs. J1 - J3). Remove old cone (e.g. cut open with knife). Take off chain. Place neck of new cone in hot water (approx 80°C/180°F) and pull onto bearing housing (Fig. L1).
2. Turn guard cone into assembly position (Fig. L2). Further assembly instructions for guard (Figs. K1 - K5).
3. Reconnect chain if required (Fig. L3).

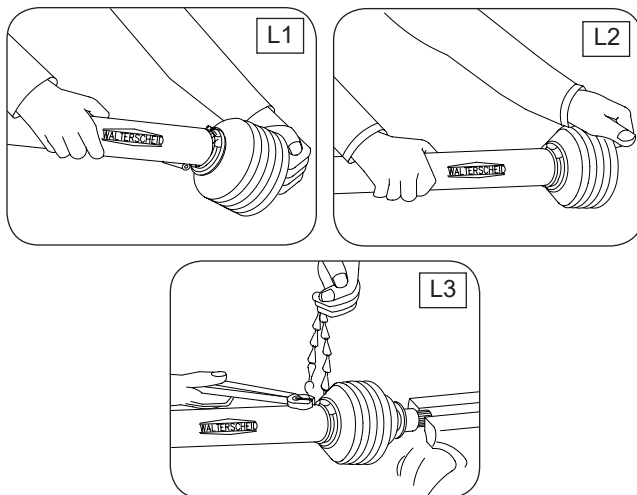

PTO Quick Disconnect

Quick Disconnect Pin

Using a drift punch and hammer, drive the pin towards the retaining washer to force the complete assembly out. Clear the edges of the retaining washer bore to accept the new one by removing the deformed metal from the last peening operation to hold the washer in place.

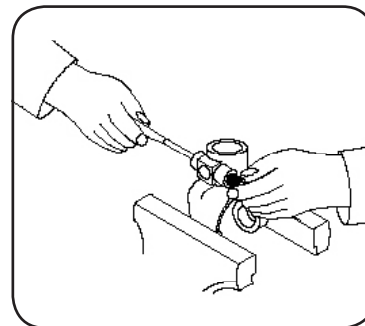
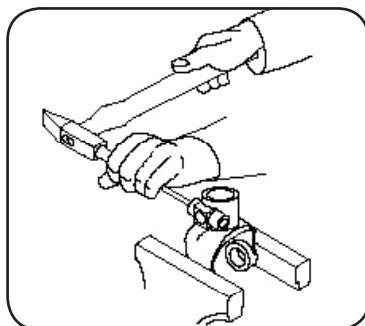
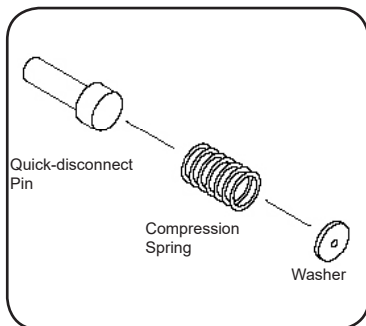

Insert quick-disconnect pin, compression spring and washer into hole, Holding the washer in place, peen the edges of the pore seat to retain the washer, spring and pin.

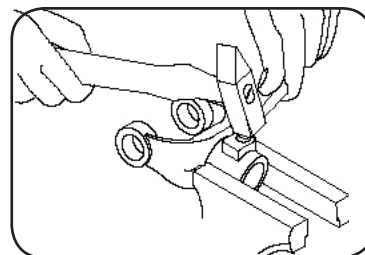
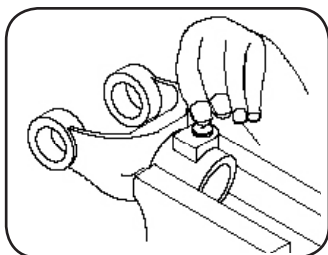
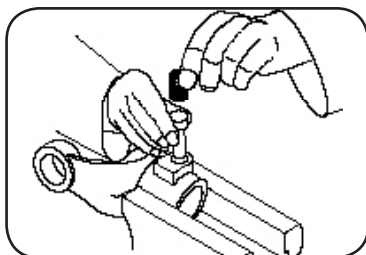

PTO Quick Disconnect (continued)

Quick Disconnect Disassembly

1. Compression Spring
2. Ball
3. Lock Collar
4. Back-up ring
5. Snap ring

* Back-up ring

* (For some clutch types, place additional back up ring first).

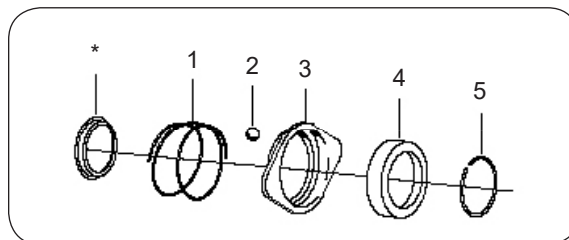

Compress lock collar (#3) and remove snap ring (#5).

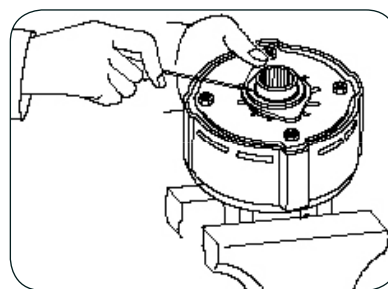

Remove back-up ring, lock collar, compression spring and balls.

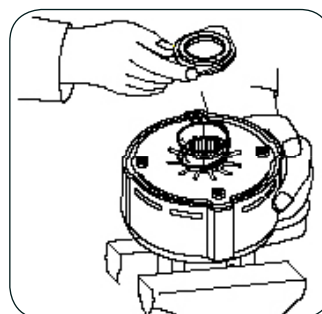

Quick Disconnect Assembly

Insert balls. Place compression spring, lock collar and back-up ring onto the hub. Remove back-up ring, lock collar, compression spring and balls.

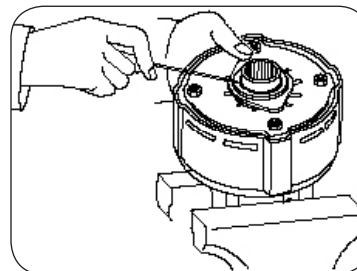
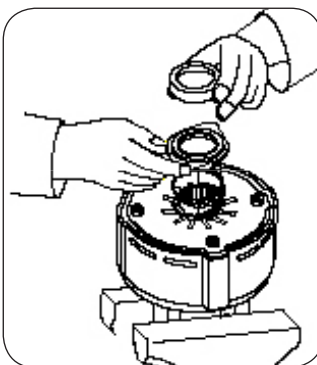
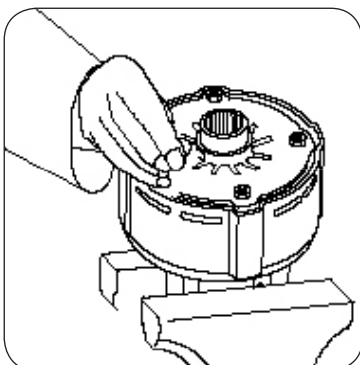

PTO Quick Disconnect (continued)

Clutch Disassembly

Tighten the four hex nuts (12) uniformly until the clutch pack and hub are loose. Use special tool 9002007 to bend all four retaining lugs back on the edge of the clutch housing. Remove the thrust plate with Belleville springs to get at the friction disks, drive plates and hub for inspection and service.

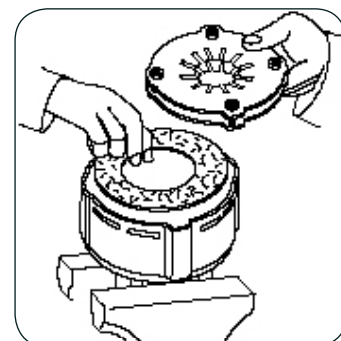
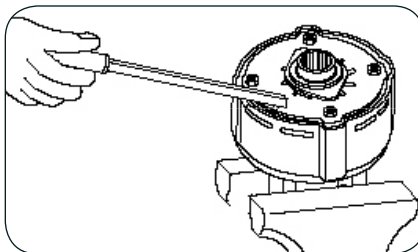
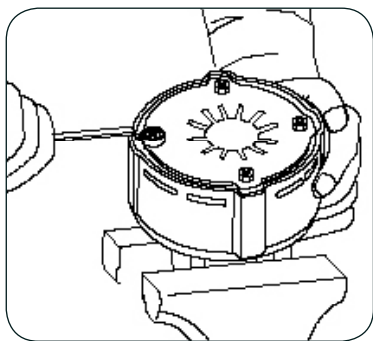

Clutch Assembly

Place hub and friction disks into the clutch housing. Note: some items are only used in the four plate clutch. Next, compress the Belleville spring(s) to the pressure plate by tightening the four hex nuts and placing them into the clutch housing as illustrated.

Use special tool #9002007 to bend the retaining lugs inward over the Belleville spring edges to secure the springs when you back the four hex nuts off. (Note: Wide lugs for one (1) Belleville spring, narrow lugs for two (2) Belleville springs).

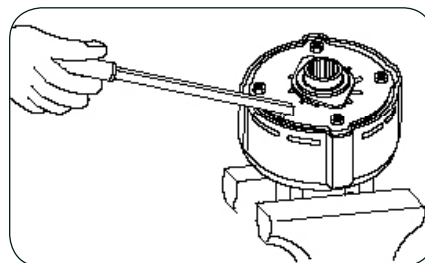
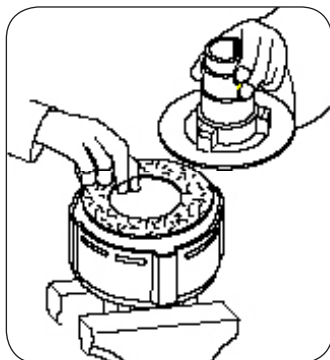

With the lugs in place, loosen the four hex nuts completely to the end of the threaded studs. Replace the quick-disconnect assembly.

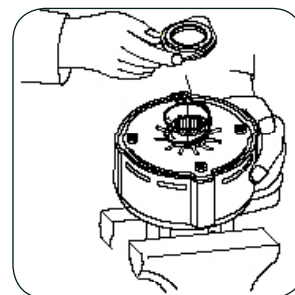
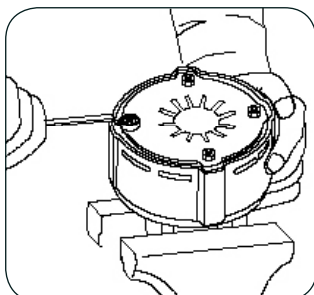

Electrical Schematic - Rear Wiring Harness #9003050

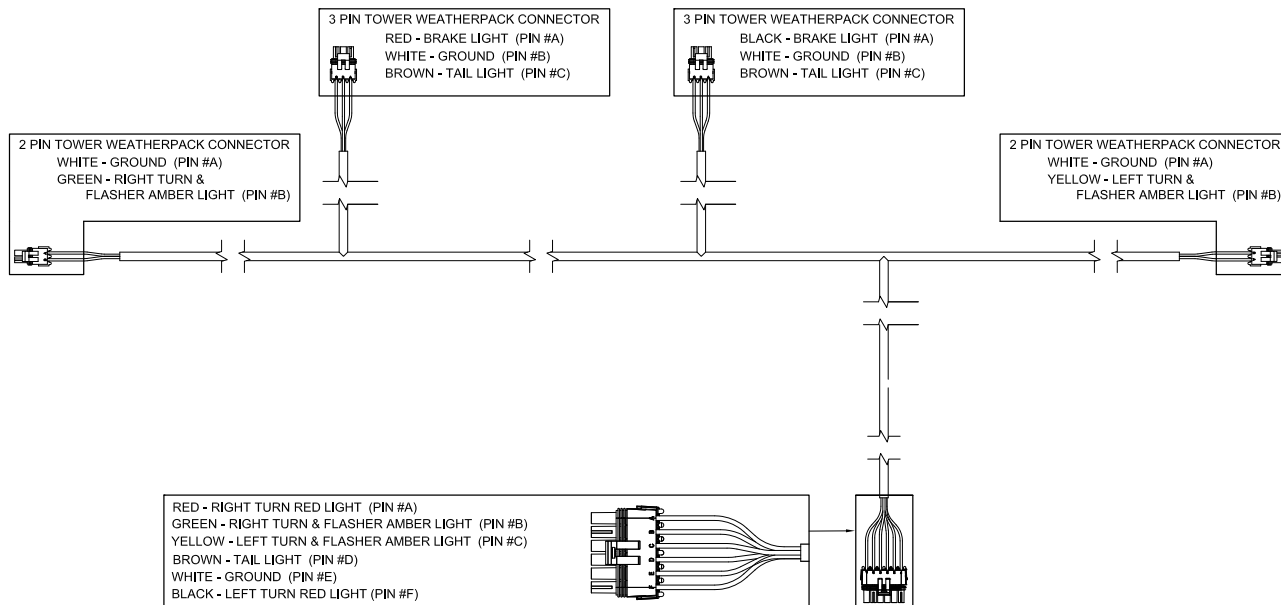

Electrical Schematic - Front Wiring Harness #9003981

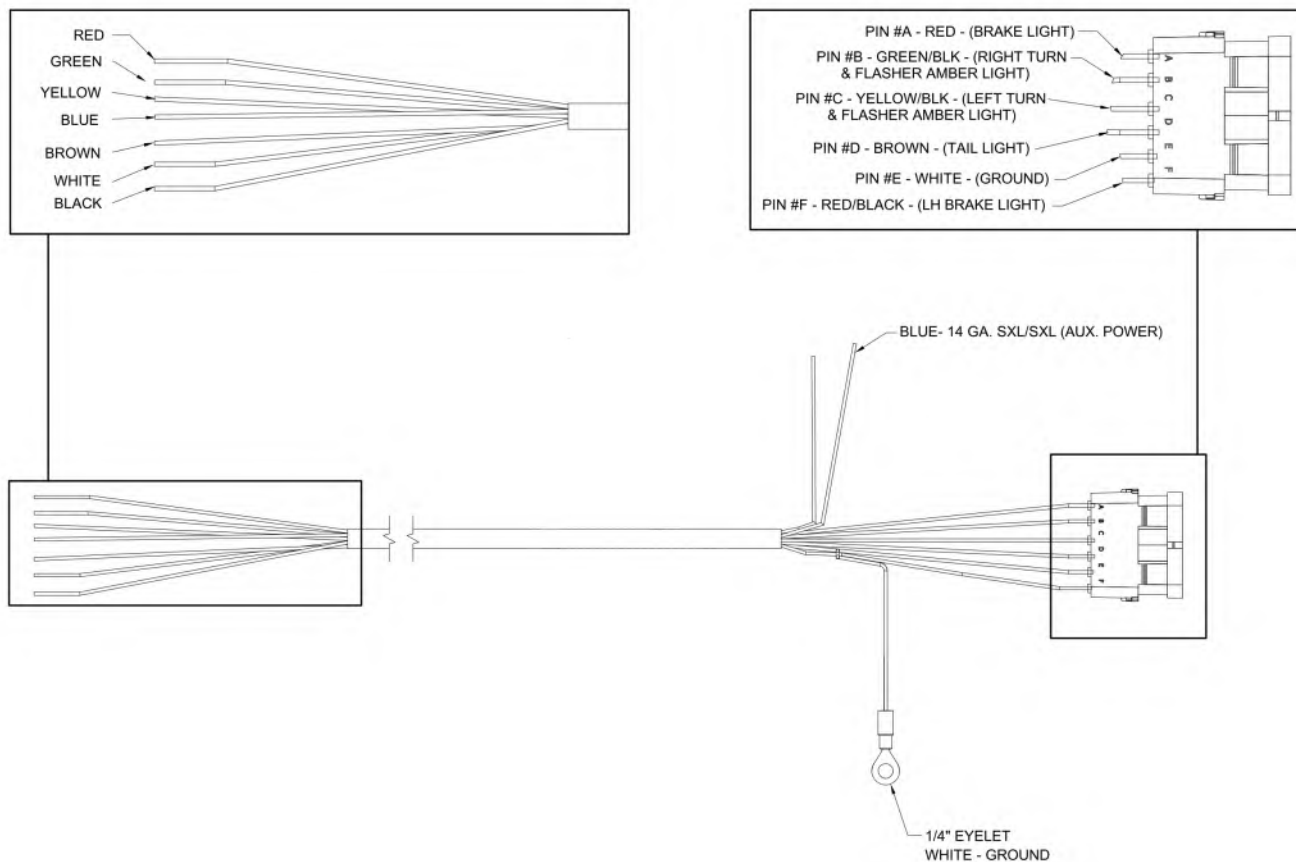

Electrical Schematic - Coupler #92450

GRAIN CART WIRES

- White -- Ground
- Green -- Right amber flashing lamp
- Yellow -- Left amber flashing lamp
- Brown -- Tail light
- Black -- Interior & Auger Lights
- Red -- Brake Lights

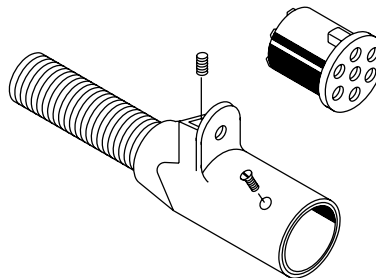

Hydraulic System Schematic

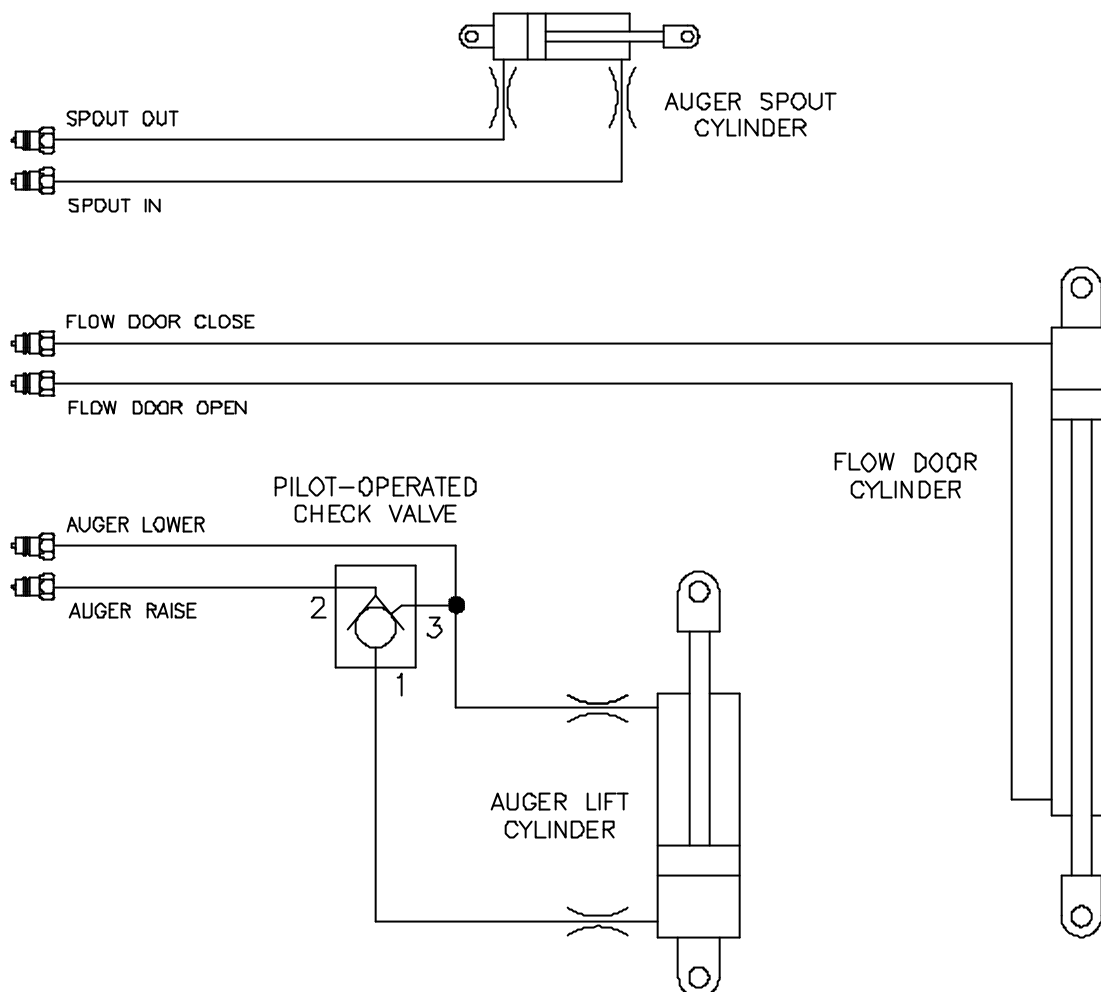

UM 520 Auto Unload Manifold Schematic

P	Hydraulic pressure from tractor
T	Hydraulic return to tractor tank
A	Flow door cylinder end that closes flow door when pressurized
B	Flow door cylinder end that opens flow door when pressurized
PS	Pressure switch
R1	Relief
S1	Solenoid 1
S2	Solenoid 2
S3	Solenoid 3

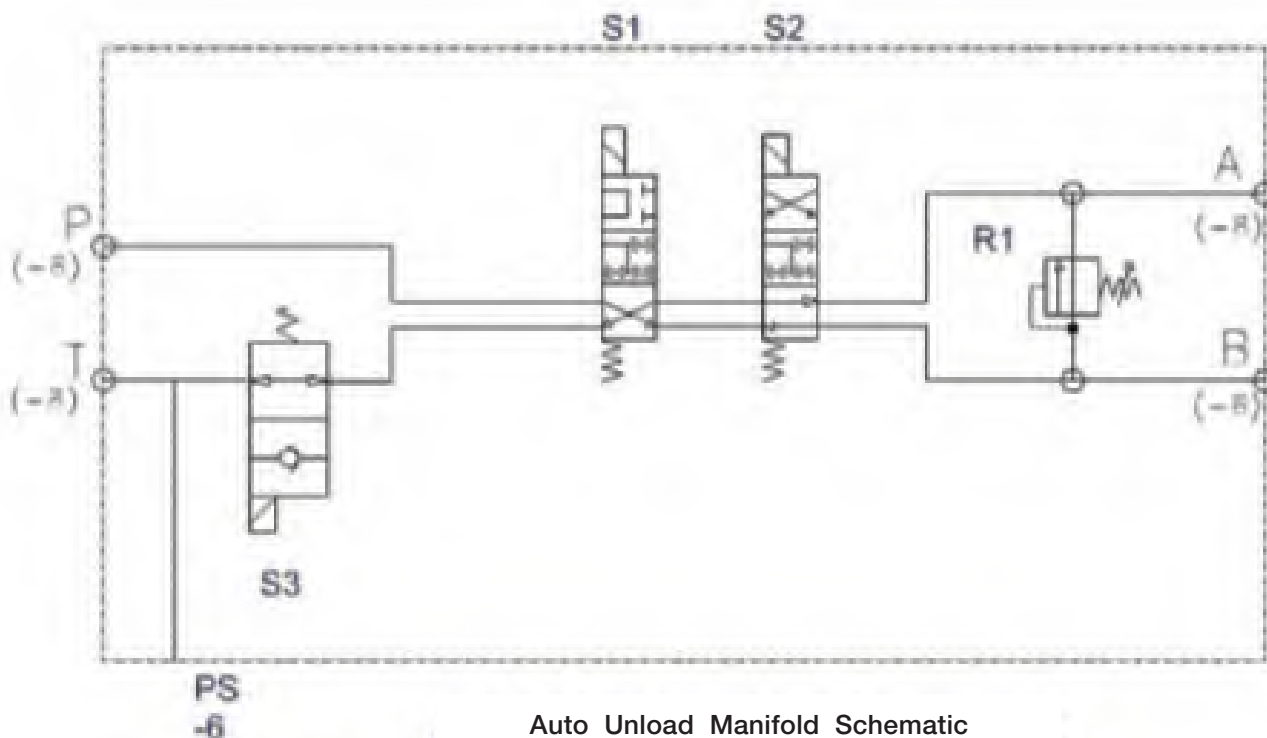

Wheels and Tires

Wheel Nut Torque Requirements

⚠ CAUTION

- IMPROPERLY TORQUED WHEEL NUTS/BOLTS CAN CAUSE A LOSS OF IMPLEMENT CONTROL AND MACHINE DAMAGE. TORQUE WHEEL NUTS/BOLTS TO VALUES IN TABLE. CHECK TORQUE BEFORE USE, AFTER ONE HOUR OF UNLOADED USE OR AFTER FIRST LOAD, AND EACH LOAD UNTIL WHEEL NUTS/BOLTS MAINTAIN TORQUE VALUE. CHECK TORQUE EVERY 10 HOURS OF USE THERE-AFTER. AFTER EACH WHEEL REMOVAL START TORQUE PROCESS FROM BEGINNING. WARRANTY DOES NOT COVER FAILURES CAUSED BY IMPROPERLY TORQUED WHEEL NUTS/BOLTS.

Failure to check torque before first load may damage wheel nut/bolt seats. Once seats are damaged, it will become impossible to keep nuts/bolts tight. Tighten nuts/bolts to applicable torque value shown in table. Start all nuts/bolts by hand to prevent cross threading. Torque nuts/bolts in the recommended sequence as shown in Diagram 1.

WHEEL HARDWARE	
SIZE	FOOT-POUNDS
3/4-16 (UNF)	365 ft.-lbs.
7/8-14 (UNF)	440 ft.-lbs.
M22x1.5	475 ft.-lbs.

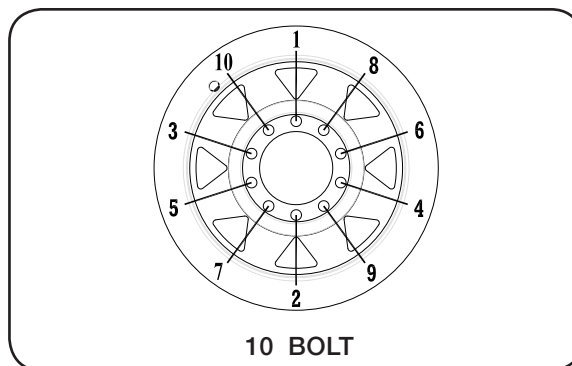

10 BOLT

DIAGRAM 1

Wheels and Tires (continued)

Tire Pressure

The following is to be used as a general guide for tire inflation and figures can vary depending on specific brand of tire used. **It is important that tires are inspected after unit is loaded.** Start with minimum pressure indicated. The tire should stand up with no side-wall buckling or distress as tire rolls. Record the pressure needed to support the full load and maintain this pressure to achieve proper tire life. **Do not exceed maximum recommended tire pressure.** Each tire must be inflated to 35 PSI max to seat the beads, deflated to 5-10 PSI, then reinflated to the tire's max PSI when mounting.

Unverferth - Tire Pressure for Grain Carts

	Tire Size	Load Index / Ply Rating	Max. PSI
Firestone	23.1x26 R-3	12	32
	23.1x26 R-1	12	32
	28Lx26 R-3	12	26
	24.5x32 R-3	12	32
	24.5x32 R-1	12	32
	30.5x32 R-1	14	28
	30.5x32 R-3	14	28
	30.5x32 R-3	16	34
	30.5x32 R-1	16	26
	35.5x32 R-3	20	36
	76x50.00x32 HF-3	16	40
	76x50.00x32 HF-3	20	50
	800/65R32 R-1W	172A8	44
	800/60R32 R-3	181B	46
	900/65R32 R-3	191B	46
	900/60R32 R-1	176A8	44
	1250/50R32F IF/CFO R-1WNP	201D	46
	1250/50R32F IF/CFO R-1W	188B	30
	520/85R38 R-1	155A8	29
	520/85R38 R-1	173A8	64
	480/80R42 R-1	151A8	36
	520/85R42 R-1	157A8	29
	520/85R42 R-1	165A8	51
	520/85R42 IF/CFO R-1	169A8/B	35
	520/85R42 R-1W	169B	35
	420/80R46 R-1	151A8	44
	480/80R46 R-1	158A8	44
380/90R46 R-1	152B	51	

Wheels and Tires (continued)

Tire Pressure (continued)

	Tire Size	Load Index / Ply Rating	Max. PSI
Titan/Goodyear	23.1x26 R-3	10	26
	23.1x26 R-1	10	26
	24.5R32 R-1	169A8/B (5-Star)	48
	24.5x32 R-3	12	32
	24.5x32 R-1	12	32
	30.5x32 R-3	16	26
	30.5x32 R-3	14	22
	30.5x32 R-1	14	22
	480/80x42 R-1	166A8	23
	1100/45R46 F-1W	195D	35
Mitas	650/75R32 R-1W	172A8	58
	900/60x32 R-1W	176A8	41
	900/70R32 R-1W	188A8	53
	1050/50x32 R-1W	178A8	41
	1250/50R32 R-1W	188A8	41
	900/60x38 R-1W	181A8	44
	520/85x42 R-1W	162A8	44
	650/65x42 R-1W	168A8	44
Alliance	35.5LR32	193A8	44
	900/60R32 R-1W	192D	46
	1050/50R32 R-1W	185A8	63
Trelleborg	900/60x32 R-1	181A8	55
	900/60x32	176LI	44

*Each tire must be inflated to 35 PSI max to seat the beads, deflated to 5-10 PSI, then reinflated to the tire's max PSI.

Tire Warranty

For questions regarding new tire warranty, please contact your local original equipment tire dealer. Used tires carry no warranty. Following are phone numbers and Websites for your convenience:

Firestone	www.firestoneag.com Phone 800-847-3364	Trelleborg	www.trelleborg.com Phone 866-633-8473
Titan or Goodyear	www.titan-intl.com Phone 800-USA-BEAR Fax 515-265-9301	Continental/Mitas	www.mitas-tires.com Phone 704-542-3422 Fax 704-542-3474
		Alliance	www.atgtire.com Phone 781-325-3801

Complete Torque Chart

Capscrews - Grade 5

NOTE:

- Grade 5 capscrews can be identified by three radial dashes on the head.
- For wheel torque requirements, refer to Wheels and Tires.
- Tighten U-bolts evenly and equally to have the same number of threads exposed on each end.



SIZE	FOOT POUNDS	NEWTON METERS
1/4-20 1/4-28	8-10 9-11	11-13 12-15
5/16-18 5/16-24	15-17 17-19	20-23 23-26
3/8-16 3/8-24	25-28 28-31	34-38 38-42
7/16-14 7/16-20	40-45 45-50	54-61 61-68
1/2-13 1/2-20	62-68 68-75	84-92 92-102
9/16-12 9/16-18	90-98 100-110	122-133 134-148
5/8-11 5/8-18	120-135 124-137	162-183 168-186
3/4-10 3/4-16	200-220 210-230	270-300 285-310
7/8-9 7/8-14	330-350 360-380	425-475 460-515
1-8 1-14	500-525 540-560	675-710 730-760
1 1/8-7 1 1/8-12	600-635 665-700	815-860 920-950
1 1/4-7 1 1/4-12	850-895 940-990	1150-1215 1275-1340
1 3/8-6 1 3/8-12	1125-1175 1280-1335	1525-1590 1735-1810
1 1/2-6 1 1/2-12	1500-1560 1685-1755	2035-2115 2285-2380

IMPORTANT

- Follow these torque recommendations except when specified in text.

Complete Torque Chart

Capscrews - Grade 8

NOTE:

- Grade 8 capscrews can be identified by six radial dashes on the head.
- For wheel torque requirements, refer to Wheels and Tires.
- Tighten U-bolts evenly and equally to have the same number of threads exposed on each end.



SIZE	FOOT POUNDS	NEWTON METERS
5/16-18	20-22	27-30
5/16-24	21-23	28-31
3/8-16	35-39	47-53
3/8-24	36-41	49-55
7/16-14	54-58	73-78
7/16-20	55-60	75-80
1/2-13	82-88	110-120
1/2-20	94-99	125-135
9/16-12	127-134	170-180
9/16-18	147-155	199-210
5/8-11	160-170	215-230
5/8-18	165-175	225-235
3/4-10	280-295	380-400
3/4-16	330-365	445-495
7/8-9	410-430	555-580
7/8-14	420-440	570-595
1-8	630-650	850-880
1-14	680-700	920-950
1 1/8-7	900-930	1220-1260
1 1/8-12	930-950	1260-1290
1 1/4-7	1250-1300	1695-1760
1 1/4-12	1280-1320	1735-1790

IMPORTANT

- Follow these torque recommendations except when specified in text.

Hydraulic Fittings - Torque and Installation

SAE Flare Connection (J. I. C.)

1. Tighten nut with finger until it bottoms the seat.
2. Using a wrench, rotate nut to tighten. Turn nut 1/3 turn to apply proper torque.

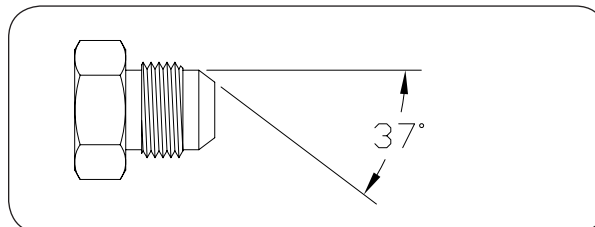

SAE Straight Thread O-Ring Seal

1. Insure jam nut and washer are backed up to the back side of smooth portion of elbow adapter.
2. Lubricate o-ring
3. Thread into port until washer bottoms onto spot face.
4. Position elbows by backing up adapter.
5. Tighten jam nut.

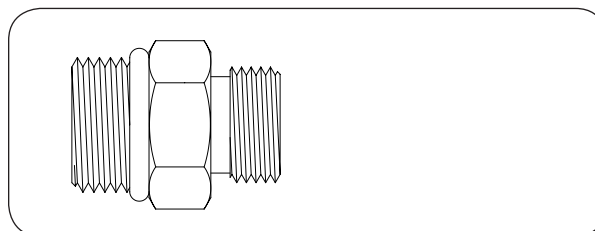

Section V Parts

Please visit www.unverferth.com/parts/ for the most current parts listing.

Final Assembly	5-2
Touch-Up Paint.....	5-3
Rigid Axle Single Wheel	5-4
Adjustable Axle Single Wheel	5-6
Adjustable Axle - Dual Wheels.....	5-8
Track Bundle Components	5-10
Track Axle Components	5-11
Hub - Rigid - Single Wheels	5-12
Hub - Adjustable Axle - Single Wheels.....	5-13
Hub - Adjustable Axle - Dual Wheels.....	5-14
Dual Wheels & Tires.....	5-15
Single Wheels & Tires	5-16
Decals	5-18
Sideboards.....	5-20
Electrical.....	5-22
Drive Components.....	5-24
Auger Components.....	5-26
Auger Fold Indicator	5-29
Cleanout Door Assembly.....	5-30
Flow Door Seals	5-31
Cylinders.....	5-32
Hydraulics.....	5-34
Directional Spout.....	5-36
PTO Assembly Shear-Bolt Clutch.....	5-38
PTO Assembly Friction Clutch.....	5-40
Friction Clutch.....	5-41
Shear-Bolt Clutch	5-42
45 Degree Gear Box	5-43
Driveline U-Joint Assembly	5-44
Video System Option	5-46

FOR TRACK INFORMATION, PLEASE REFER TO YOUR TRACK MANUAL.

FOR TARP INFORMATION, PLEASE REFER TO YOUR TARP MANUAL.

FOR SCALE INFORMATION, PLEASE REFER TO YOUR SCALE MANUAL.

FOR HYDRAULIC DRIVE INFORMATION, PLEASE REFER TO YOUR HYDRAULIC DRIVE MANUAL.

Final Assembly

Please visit www.unverferth.com/parts/ for the most current parts listing.

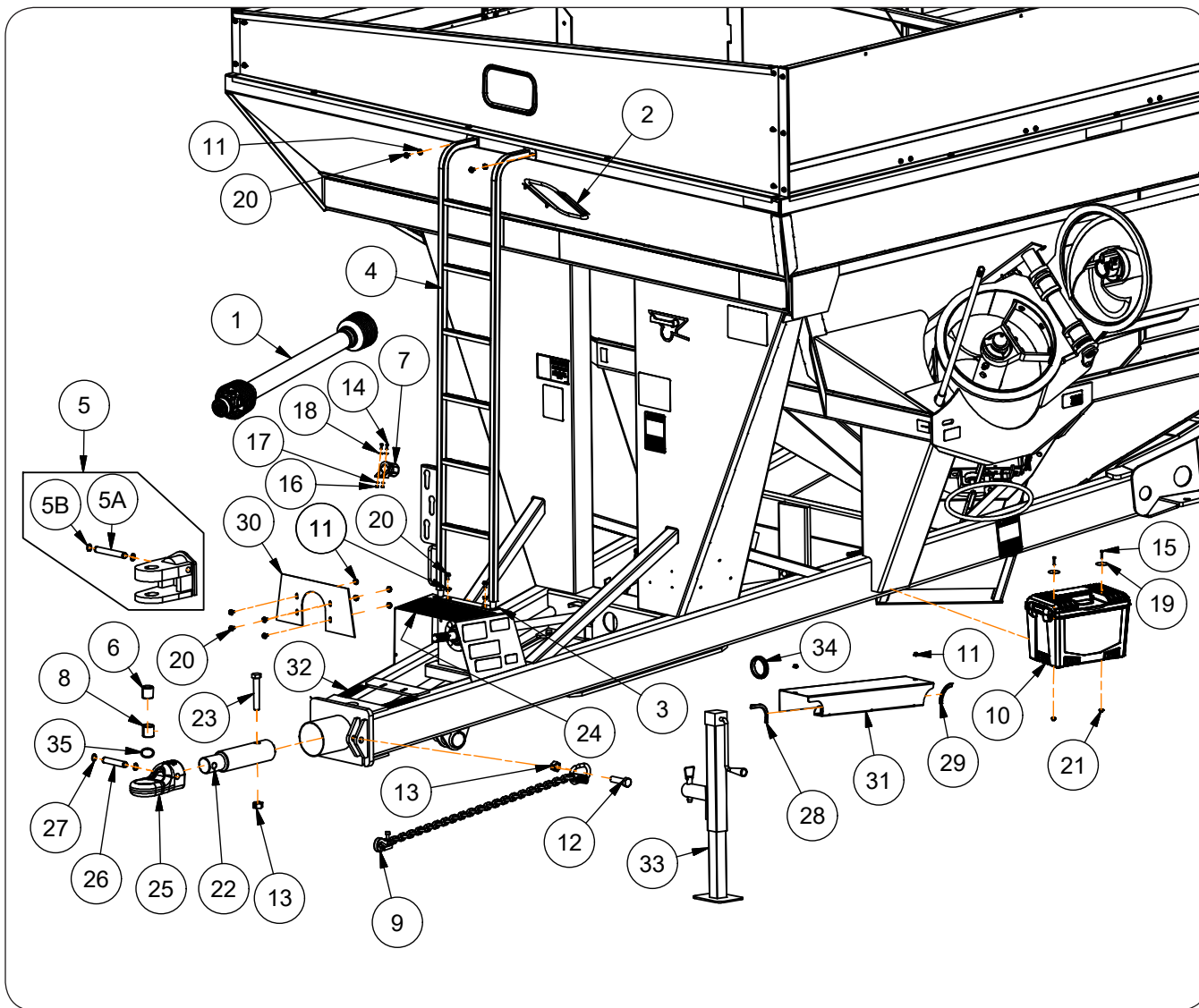

ITEM	DESCRIPTION	PART NO.	QTY.	NOTES
1	PTO Assembly	-	1	Refer to "PTO Assembly" in Parts Section for Items
2	Window	92403	2	
	Window Molding	271951	2	
	Bracket, Window Retainer	250461B	4	
	Capscrew 1/4-20UNC x 3/4	9390-003	8	Grade 5
	Large Flange Hex Nut 1/4-20UNC	97189	8	
3	Ladder Bracket Weldment	250480B	1	
4	Ladder Weldment	280600B	1	
5	Clevis Hitch Kit	281690	Opt.	Includes Items 5A & 5B
5A	Pin 1" Dia. x 7 3/8"	281691	1	
5B	Retaining Ring 1"	91192	2	
6	Tension Bushing 2 OD x 1.516 ID x 2	9001917	1	
7	Connector Holder	9001968	1	

Final Assembly

Please visit www.unverferth.com/parts/ for the most current parts listing.

8	Split Tension Bushing 2 OD x 1 3/4 ID x 2	9002130	1	
9	Transport Chain	9003278	1	
10	Storage Box	9005850	1	
11	Nut/Large Flange 3/8-16UNC	91263	6	Grade 5
12	Capscrew 1-8UNC x 3 1/2	91299-189	1	Grade 8
13	Locknut 1-8UNC	92199	1	
14	Capscrew 1/4-20UNC x 3/4	9390-003	2	Grade 5
15	Capscrew 1/4-20UNC x 1 1/4	9390-006	2	Grade 5
16	Hex Nut 1/4-20UNC	9394-002	2	
17	Lock Washer 1/4	9404-017	2	
18	Flat Washer 1/4"	9405-064	4	
19	Fender Washer	94763	2	
20	Capscrew/Large Flange 3/8-16UNC x 3/4	95585	6	Grade 5
21	Large Flange Hex Nut 1/4-20UNC	97189	8	
22	Hitch Bar 3 3/4" Dia.	284780	1	
23	Capscrew 1"-8UNC x 6" G8	91299-195	1	
24	Platform Rubber Pad	9004114	1	
25	Hitch, Single Tang	282875B	1	
26	Pin 1" Dia. x 5 1/2	282876	1	
27	Retaining Ring 1"	91192	2	
28	Trim-Edge	2006214	1	
29	Trim-Edge	2006215	1	
30	Driveshaft Cover Plate	280554B	1	
31	Driveshaft Cover	280605B	1	
32	Runner Pad	9001498	2	
33	Jack Assembly w/Pin	9004156	1	
	Pin 7/8" Dia.	9004171	-	
34	Rubber Grommet	9006780	3	
35	O-Ring	9005259	4	

Touch-Up Paint

Please visit www.unverferth.com/parts/ for the most current parts listing.

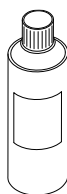

PAINT	SPRAY
Black	97013
Green	97015
Red	97301
Primer, Gray	9000592
Off White	97016

Rigid Axle — Single Wheel

Please visit www.unverferth.com/parts/ for the most current parts listing.

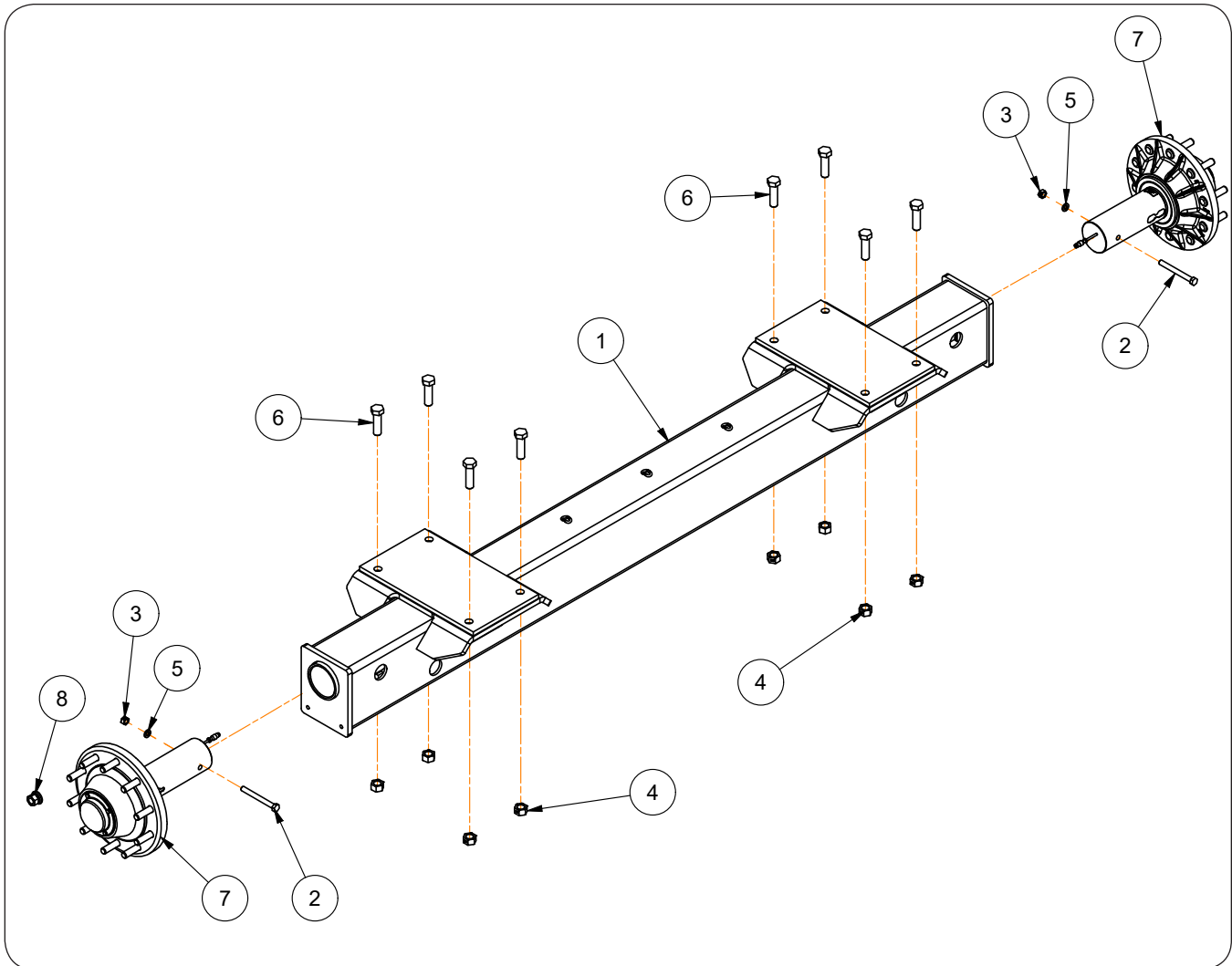

Rigid Axle — Single Wheel

Please visit www.unverferth.com/parts/ for the most current parts listing.

ITEM	DESCRIPTION	PART NO.	QTY.	NOTES
	Rigid Axle Bundle, Scale =Green=	2006246G	1	Items 1-7
	Rigid Axle Bundle, Scale =Red=	2006246R		
	Rigid Axle Bundle, Non-Scale =Green=	2006247G		
	Rigid Axle Bundle, Non-Scale =Red=	2006247R		
1	Axle Tube Weldment =Green=	2006244G	1	
	Axle Tube Weldment =Red=	2006244R		
2	Capscrew, 5/8"-11UNC x 6" G5	9390-136	2	
3	Lock Nut/Center 5/8"-11UNC	95905	2	
4	Lock Nut 1"-8UNC	92199	8	
5	Lock Washer 5/8"	9404-029	2	
6	Capscrew 1"-8UNC x 3 1/2" G5	9390-189	8	
7	Hub & Spindle Assembly, Scale, M22 Wheel Nuts =Green=	267280G	2	Shown Includes Item 8
	Hub & Spindle Assembly, Scale, M22 Wheel Nuts =Red=	267280R		
	Hub & Spindle Assembly, Non-Scale, M22 Wheel Nuts =Green=	267284G	2	Includes Item 8
	Hub & Spindle Assembly, Non-Scale, M22 Wheel Nuts =Red=	267284R		
8	M22 x 1.5 Flanged Cap Nut	97319	20	
	M22 Wheel Nut Kit	267500	-	

Adjustable Axle — Single Wheel

Please visit www.unverferth.com/parts/ for the most current parts listing.

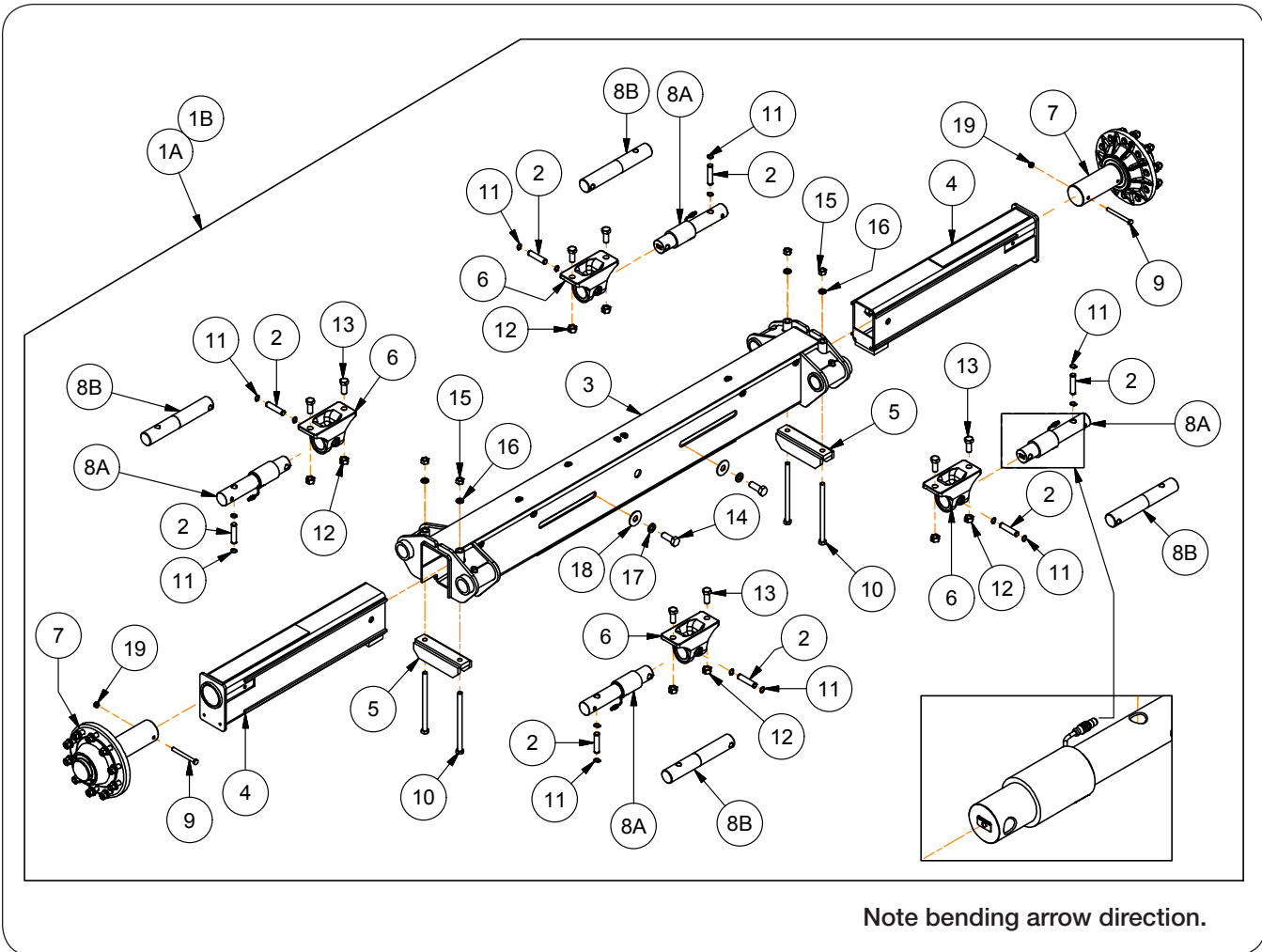

Adjustable Axle — Single Wheel

Please visit www.unverferth.com/parts/ for the most current parts listing.

ITEM	DESCRIPTION	PART NO.	QTY	NOTES
1A	Adjustable Axle Bundle, Scale =Green=	280489G	-	Includes Items 2-7, 8A, 9-19
	Adjustable Axle Bundle, Scale =Red=	280489R		
1B	Adjustable Axle Bundle, Non-Scale =Green=	280576G	-	Includes Items 2-7, 8B, 9-19
	Adjustable Axle Bundle, Non-Scale =Red=	280576R		
2	Pin 1" Dia. x 4 9/16	250843	8	
3	Axle Weldment =Green=	280106G	1	
	Axle Weldment =Red=	280106R		
4	Axle Extension Tube Weldment	280135B	2	
5	Axle Clamp Weldment	280789B	2	
6	Axle Mount Casting =Green=	283855G	4	
	Axle Mount Casting =Red=	283855R		
7	Hub & Spindle Kit =Green=	267284G	2	Kit Includes Wheel Nuts
	Hub & Spindle Kit =Red=	267284R		
8A	Scale Load Cell 2.875" Dia.	9004903	4	
8B	Bar 2.875" Dia.	268289		
9	Capscrew 5/8-11UNC x 6 1/4	9007387	2	Grade 5
10	Capscrew 7/8-9UNC x 14	9007566	4	Grade 5
11	Retaining Ring 1"	91192	16	
12	Locknut 1-8UNC	92199	8	
13	Capscrew 1-8UNC x 2 1/2	9390-185	8	Grade 5
14	Capscrew 1 1/8-7UNC x 3	9390-200	2	Grade 5
15	Hex Nut 7/8-9UNC	9394-018	4	
16	Lock Washer 7/8	9404-037	4	
17	Lock Washer 1 1/8	9404-045	2	
18	Washer 1 1/8" Heavy Duty	289325	2	
19	Locknut 5/8-11UNC	95905	2	

Adjustable Axle — Dual Wheels

Please visit www.unverferth.com/parts/ for the most current parts listing.

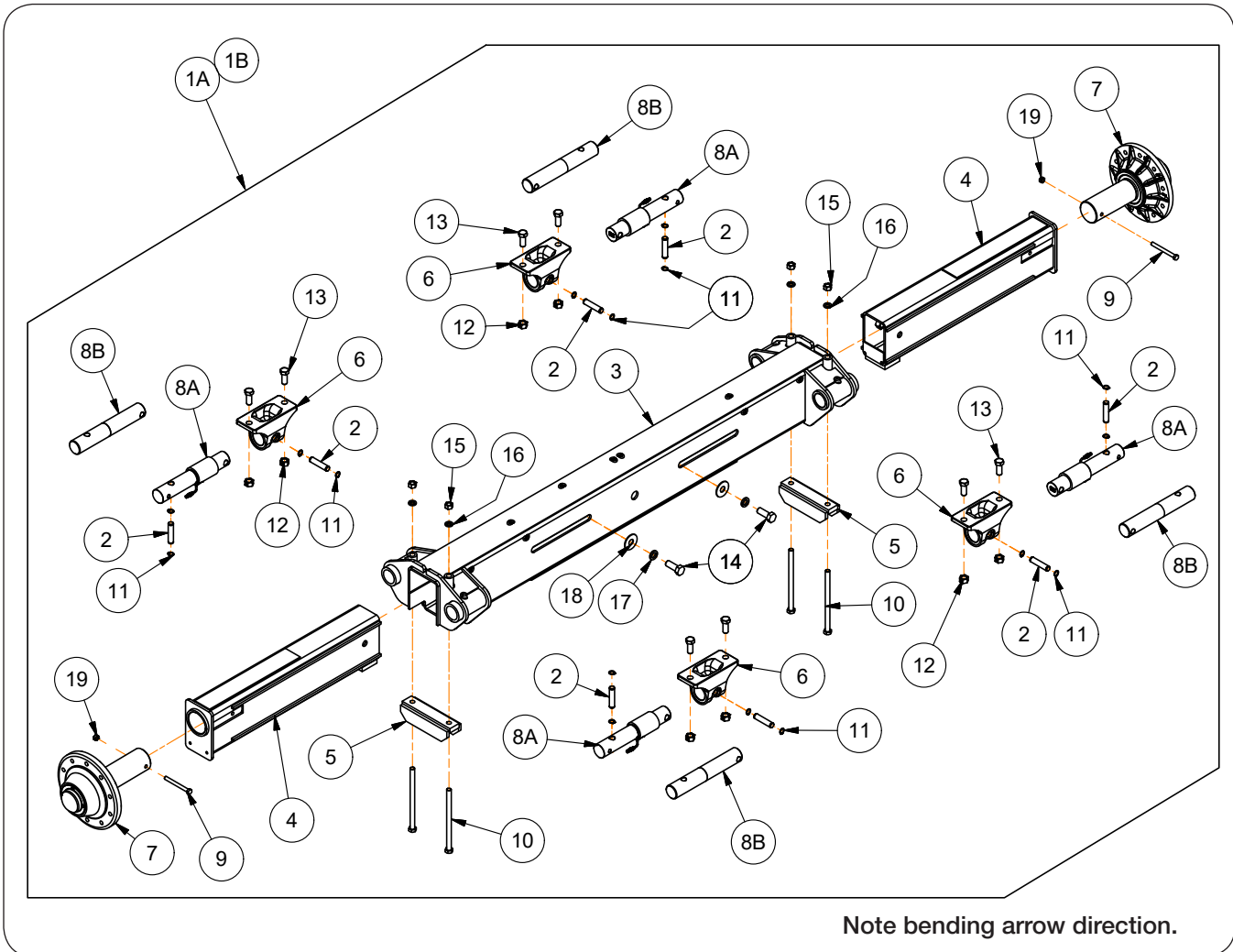

Note bending arrow direction.

Adjustable Axle — Dual Wheels

Please visit www.unverferth.com/parts/ for the most current parts listing.

ITEM	DESCRIPTION	PART NO.	QTY	NOTES
1A	Adjustable Axle Bundle, Scale =Green=	2006452G	-	Includes Items 2-7, 8A, 9-19
	Adjustable Axle Bundle, Scale =Red=	2006452R		
1B	Adjustable Axle Bundle, Non-Scale =Green=	2006453G	-	Includes Items 2-7, 8B, 9-19
	Adjustable Axle Bundle, Non-Scale =Red=	2006453R		
2	Pin 1" Dia. x 4 9/16	250843	8	
3	Axle Weldment =Green=	280106G	1	
	Axle Weldment =Red=	280106R		
4	Axle Extension Tube Weldment	280135B	2	
5	Axle Clamp Weldment	280789B	2	
6	Axle Mount Casting =Green=	283855G	4	
	Axle Mount Casting =Red=	283855R		
7	Hub & Spindle Assembly=Green=	284269G	2	
	Hub & Spindle Assembly =Red=	284269R		
8A	Scale Load Cell 2.875" Dia.	9004903	4	
8B	Bar 2.875" Dia.	268289		
9	Capscrew 5/8-11UNC x 6 1/4	9007387	2	Grade 5
10	Capscrew 7/8-9UNC x 14	9007566	4	Grade 5
11	Retaining Ring 1"	91192	16	
12	Locknut 1-8UNC	92199	8	
13	Capscrew 1-8UNC x 2 1/2	9390-185	8	Grade 5
14	Capscrew 1 1/8-7UNC x 3	9390-200	2	Grade 5
15	Hex Nut 7/8-9UNC	9394-018	4	
16	Lock Washer 7/8	9404-037	4	
17	Lock Washer 1 1/8	9404-045	2	
18	Washer 1 1/8" Heavy Duty	289325	2	
19	Locknut 5/8-11UNC	95905	2	

Track Bundle Components

Please visit www.unverferth.com/parts/ for the most current parts listing.

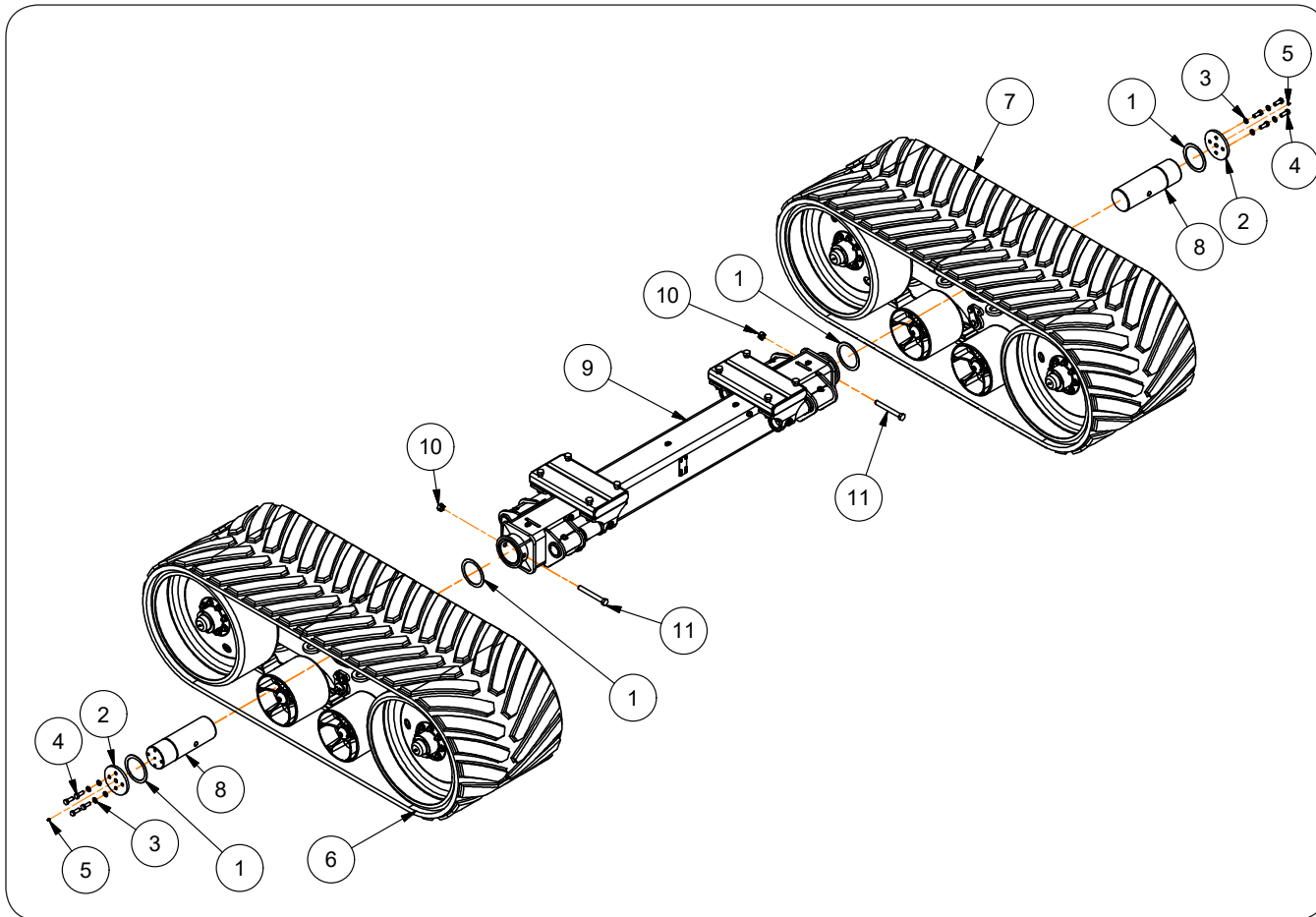

ITEM	DESCRIPTION	PART NO.	QTY.	NOTES
1	Washer, 7 1/2"	268619	4	
2	Cover Plate =Black=	268121B	2	
3	Lock Washer, 3/4"	9404-033	8	
4	Cap screw, 3/4-10UNC x 2 Gr.5	9390-145	8	
5	Grease Zerk	93426	2	
6	Track Assembly, Left-Hand	267140B	1	
7	Track Assembly, Right-Hand	267141B	1	
8	Axle Pivot Shaft	267124	2	
9	Track Axle Bundle, Scale =Green=	287906G	1	
	Track Axle Bundle, Scale =Red=	287906R		
	Track Axle Bundle, Non-Scale =Green=	287907G		
	Track Axle Bundle, Non-Scale =Red=	287907R		
10	Center Locknut, 1-8UNC	92199	2	
11	Cap screw, 1-8UNC x 8 1/2 Gr.5	9390-462	2	

FOR TRACK INFORMATION, PLEASE REFER TO YOUR TRACK MANUAL.

Track Axle Components

Please visit www.unverferth.com/parts/ for the most current parts listing.

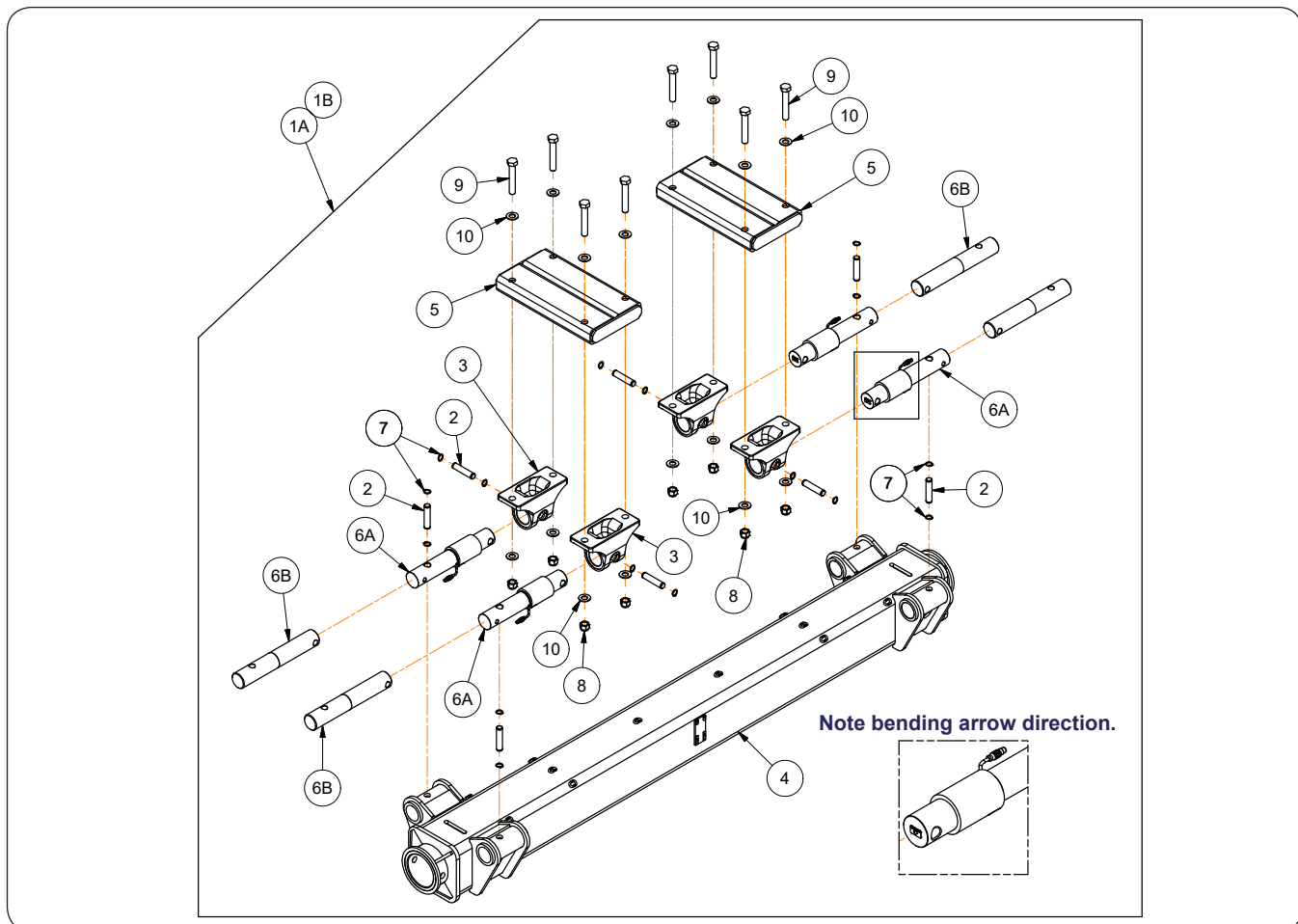

ITEM	DESCRIPTION	PART NO.	QTY	NOTES
1A	Track Axle Bundle, Scale =Green=	287906G	-	Includes Items 1-5, 6A, 7-10
	Track Axle Bundle, Scale =Red=	287906R		
1B	Track Axle Bundle, Non-Scale =Green=	287907G	-	Includes Items 1-5, 6B, 7-10
	Track Axle Bundle, Non-Scale =Red=	287907R		
2	Pin 1" Dia. x 4 9/16	250843	8	
3	Axle Mount Casting =Green=	283855G	4	
	Axle Mount Casting =Red=	283855R		
4	Axle Weldment =Green=	287936G	1	
	Axle Weldment =Red=	287936R		
5	Riser Weldment =Green=	287945G	2	
	Riser Weldment =Red=	287945R		
6A	Scale Load Cell 2.875" Dia.	9004903	4	
6B	Bar 2.875" Dia.	268289		
7	Retaining Ring 1"	91192	16	
8	Center Locknut, 1-14UNS	9008441	8	
9	Capscrew, 1"-14UNS x 6" G8	91299-1464	8	
10	Washer 2" OD x 1 1/16" ID	804685	16	

FOR TRACK INFORMATION, PLEASE REFER TO YOUR TRACK MANUAL.

Hub — Rigid Axle — Single Wheels

Please visit www.unverferth.com/parts/ for the most current parts listing.

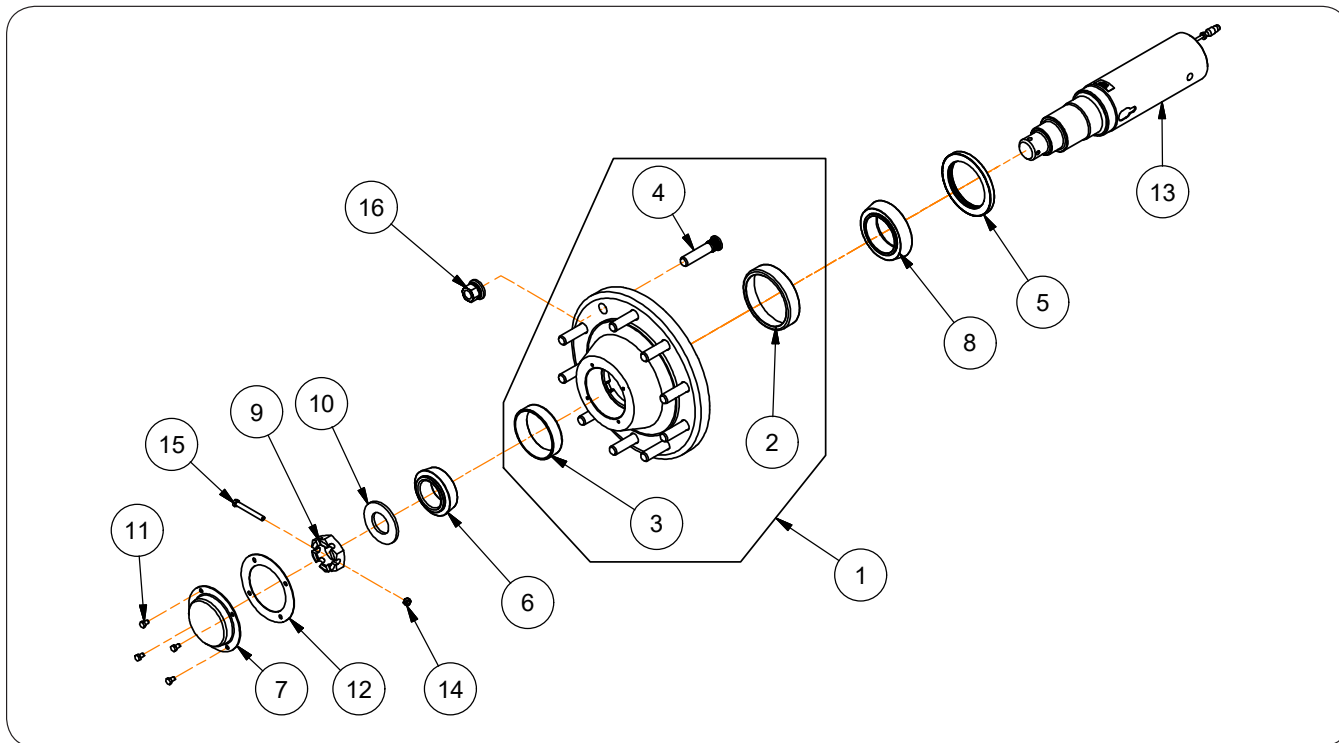

ITEM	DESCRIPTION	PART NO.	QTY	NOTES
	Hub & Spindle Asy (Green), Scale	267205G	1	Includes Items 1 through 15
	Hub & Spindle Asy (Red), Scale	267205R	1	
	Hub & Spindle Asy (Green), Non-Scale	284268G	1	Includes Items 1 through 15
	Hub & Spindle Asy (Red), Non-Scale	284268R	1	
1	Hub Sub Assembly (Green)	265390G	1	Includes Items 2, 3 & 4
	Hub Sub Assembly (Red)	265390R		
	2 Inner Cup	92476	1	HM218210
	3 Outer Cup	92462	1	HM212011
	4 Stud, M22 x 1.5 x 4	9007001	10	
5	Seal - 4.375" I.D.	92455	1	43605SA
6	Outer Bearing Cone	92464	1	HM212049
7	Hub Cap	92465	1	
8	Inner Bearing Cone	92545	1	HM218248
9	Nut	92470	1	
10	Washer	92472	1	
11	Capscrew, 5/16-18 UNC x 1/2	9390-026	4	
12	Gasket	284230	1	
13	Spindle 4 1/2" Dia. - Scale	9006348	1	SHOWN
	Spindle 4 1/2" Dia. - Non-Scale	280240		
14	Lock Nut/Center 3/8"-16UNC	902875	1	
15	Capscrew 3/8"-16UNC x 3 1/4" G5	9390-064	1	
16	Flange Nut, M22x1.5	97319	10	

Hub — Adjustable Axle — Single Wheels

Please visit www.unverferth.com/parts/ for the most current parts listing.

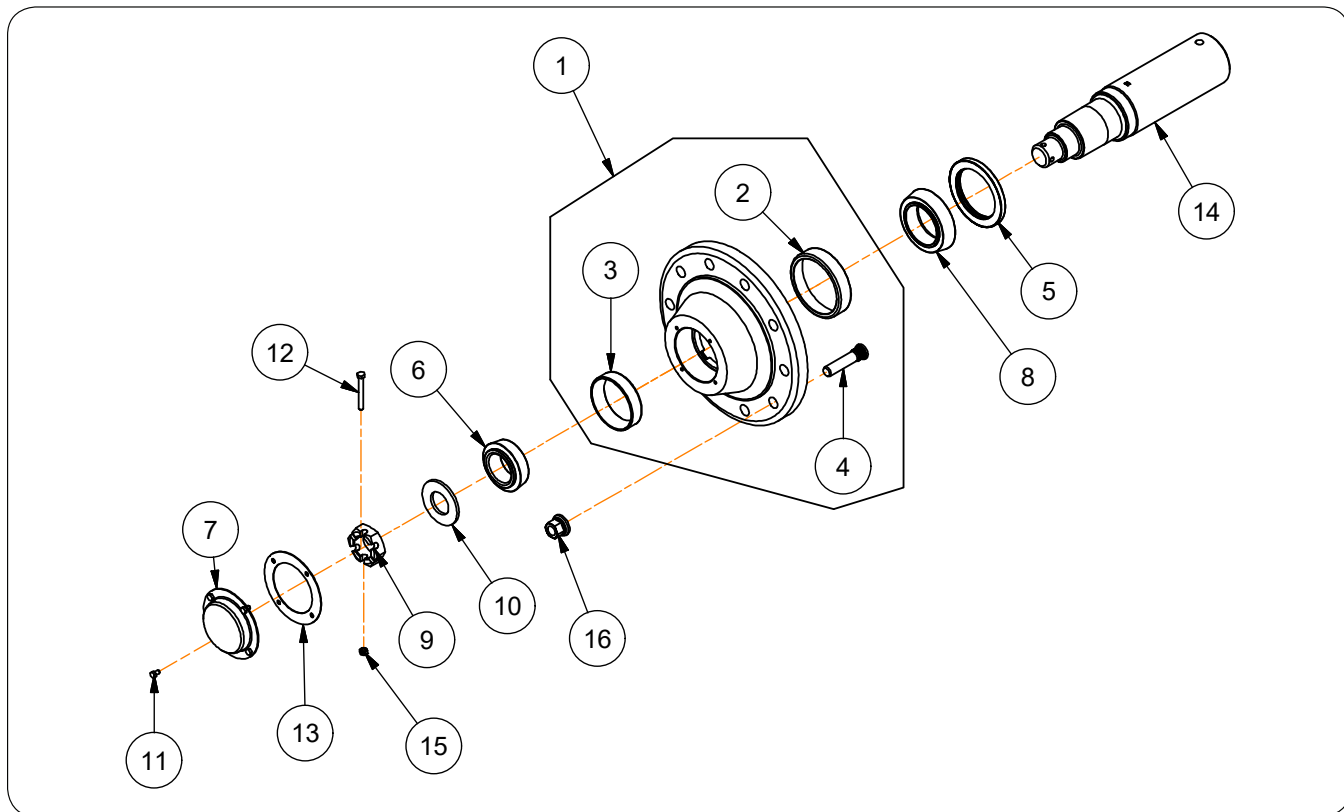

ITEM	DESCRIPTION	PART NO.	QTY	NOTES
	Hub & Spindle Assy (Green)	267284G	1	
	Hub & Spindle Assy (Red)	267284R		
1	Hub (Green)	265390G	1	Includes Items 2, 3, & 4
	Hub (Red)	265390R	1	
2	Inner Cup	92476	1	HM218210
3	Outer Cup	92462	1	HM212011
4	Stud Bolt, M22x1.5 x 4	9007001	10	
5	Seal	92455	1	43605SA/CR44320
6	Outer Bearing Cone	92464	1	HM212049
7	Hub Cap	92465	1	
8	Inner Bearing Cone	92545	1	HM218248
9	Nut	92470	1	
10	Washer	92472	1	
11	Capscrew, 5/16"-18UNC x 1/2"	9390-026	4	Grade 5
12	Capscrew, 3/8"-16UNC x 3 1/4"	9390-064	1	
13	Gasket	284230	1	
14	Spindle 4 1/2" Dia. x 19 7/8	280240	1	
15	Lock Nut/Center 3/8"-16UNC	902875	1	
16	Wheel Nut, M22 x 1.5 Kit	267275	1	

Hub — Adjustable Axle — Dual Wheels

Please visit www.unverferth.com/parts/ for the most current parts listing.

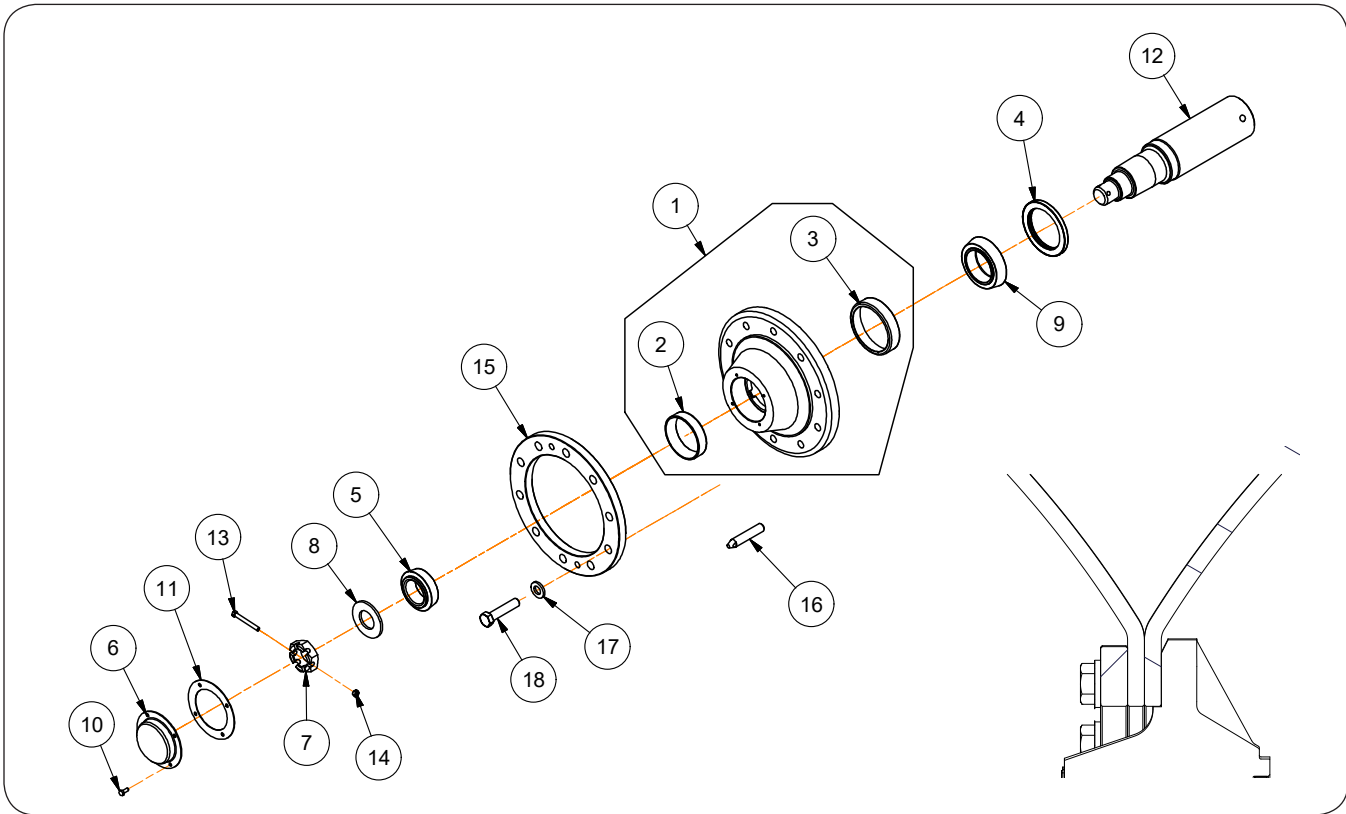

ITEM	DESCRIPTION	PART NO.	QTY.	NOTES
	Hub & Spindle Assembly (Green)	284269G		
	Hub & Spindle Assembly (Red)	284269R		
1	Hub (Green)	266455G	1	Includes Items 2 & 3
	Hub (Red)	266455R		
2	Outer Cup	92462	1	HM212011
3	Inner Cup	92476	1	HM218210
4	Seal - 4.375" I.D.	92455	1	43605SA
5	Outer Bearing Cone	92464	1	HM212049
6	Hub Cap	92465B	1	
7	Nut	92470	1	
8	Washer	92472	1	
9	Inner Bearing Cone	92545	1	HM218248
10	Capscrew, 5/16"-18UNC x 3/4"	9390-028	4	
11	Gasket	284230	1	
12	Spindle Dia. 4.50"	280240	1	
13	Capscrew, 3/8"-16UNC x 3 1/4"	9390-064	1	
14	Lock Nut/Center 3/8"-16UNC	902875	1	
15	Ring	14442	1	
16	Pin Guide 7/8" Dia. x 4 3/4"	266459	2	
17	Flat Washer, 7/8	97041	10	
18	Capscrew, 7/8"-14UNF x 4"	97043	10	Grade 8

Dual Wheels & Tires

Please visit www.unverferth.com/parts/ for the most current parts listing.

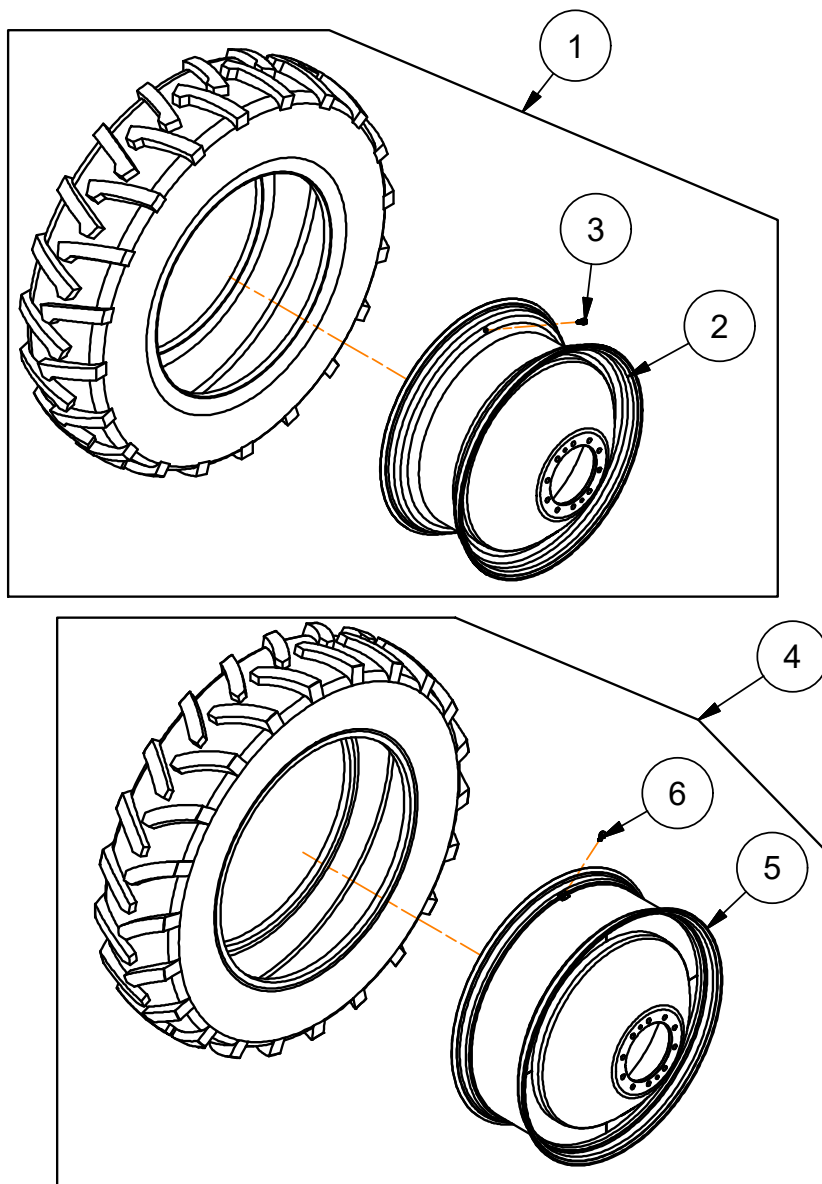

ITEM	DESCRIPTION	PART NO.	QTY.	NOTES	
1	Wheel & Tire Assembly	14565SM	4	18 x 42 / TL520/85R42F R-1 / Firestone Tire	
	2	Wheel Only	14562SM	4	18 x 42
	3	Valve Stem	93300	4	
4	Wheel & Tire Assembly	15366SM	4	16 x 46 / TL480/80R46F R-1 / Firestone Tire	
	5	Wheel Only	15365SM	4	16 x 46
	6	Valve Stem	93300	4	

Single Wheels & Tires

Please visit www.unverferth.com/parts/ for the most current parts listing.

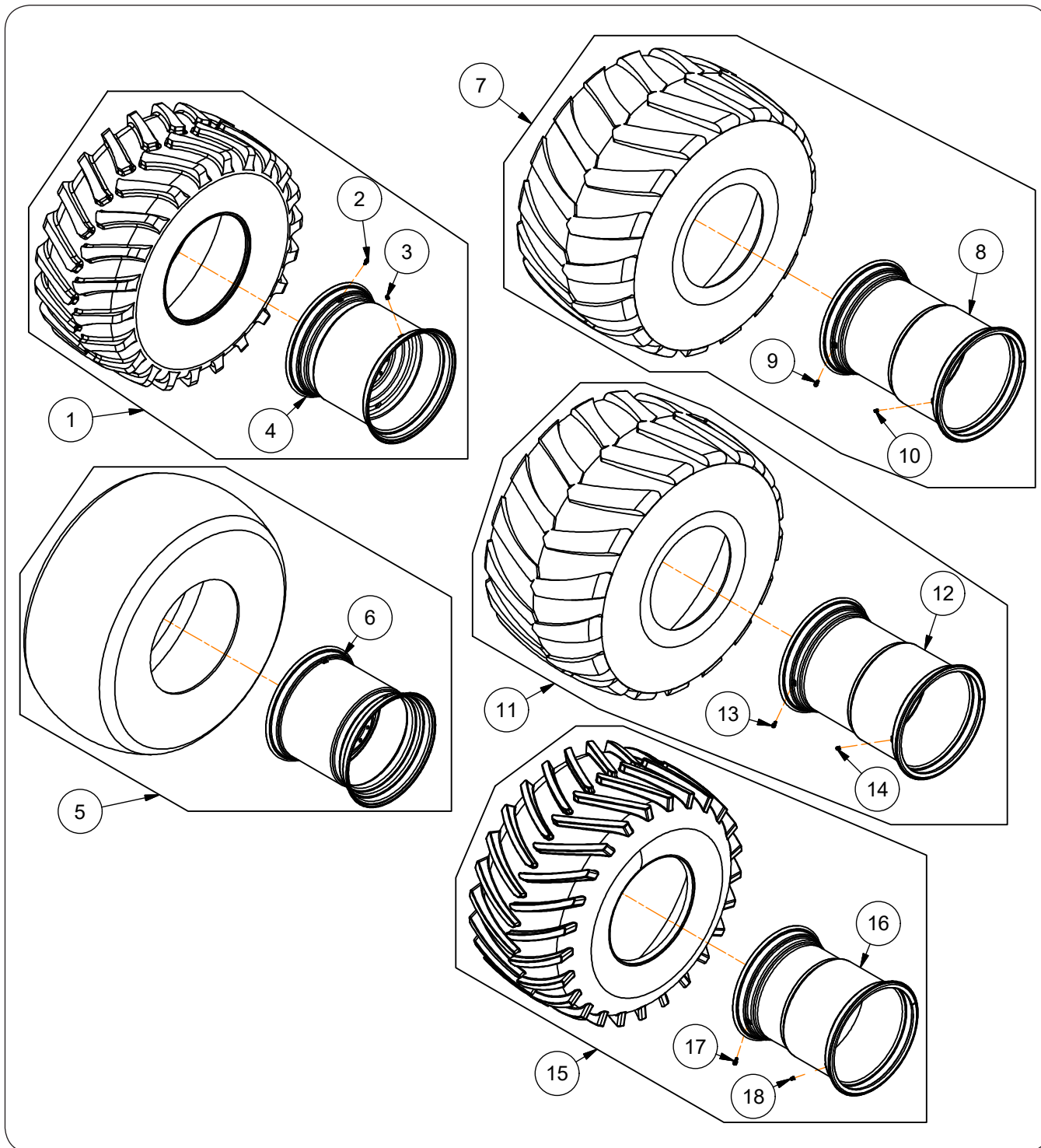

TIRES

For questions regarding new tire warranty, please contact your local original equipment tire dealer. Used tires carry no warranty.

Single Wheels & Tires

Please visit www.unverferth.com/parts/ for the most current parts listing.

STRAIGHT PLATE WHEELS						
ITEM	DESCRIPTION	PART NO.	QTY.		NOTES	
			RIGID AXLES	ADJUSTABLE AXLES		
1	Wheel & Tire Assembly	18519SM	2	2	30 x 32 / TL900/60R32 R1W / Mitas Tire	
	2	Valve Stem	93300	2		
	3	Plug, Rim Hole	95365	2		
	4	Wheel Only	903059SM	2	2	30 x 32
5	Wheel & Tire Assembly	110314M	2	2	30 x 32 / TLIF900/65R32 R3 / Firestone Tire	
	6	Wheel Only	903059SM	2	2	30 x 32
7	Wheel & Tire Assembly	19969SM	-	2	44 x 32 / TL1250/50R32 / Mitas Tire	
	8	Wheel Only	19966SM	-	2	44 x 32
	9	Valve Stem	93300	-	2	
	10	Plug, Rim Hole	95365	-	2	
11	Wheel & Tire Assembly	110313SM	-	2	44 x 32 / TLIF1250/50R32 CFO R-1W / Firestone Tire	
	12	Wheel Only	19966SM	-	2	44 x 32
	13	Valve Stem	93300	-	2	
	14	Plug, Rim Hole	95365	-	2	
15	Wheel & Tire Assembly	17923SM	-	2	36 x 32 / TL1050/50R32 / Mitas Tire	
	16	Wheel Only	17922SM	-	2	36 x 32
	17	Valve Stem	93300	-	2	
	18	Plug, Rim Hole	95365	-	2	

Decals

Please visit www.unverferth.com/parts/ for the most current parts listing.

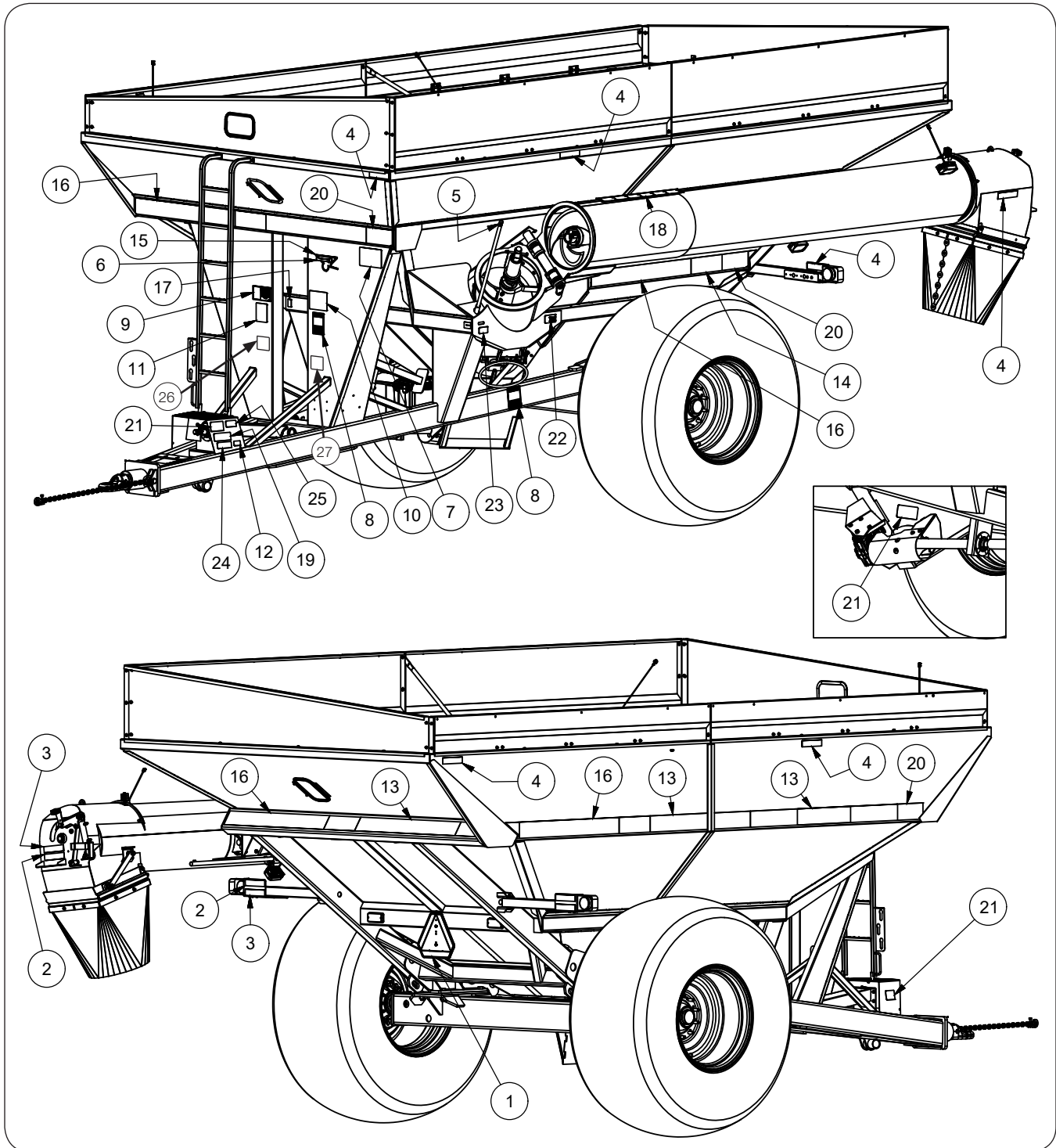

Decals

Please visit www.unverferth.com/parts/ for the most current parts listing.

ITEM	DESCRIPTION	PART NO.	QTY.	NOTES
1	SMV Sign	TA510514	1	
2	Fluorescent Strip	9003125	2	2 x 9"
3	Red Reflector	9003126	2	2 x 9"
4	Amber Reflector	9003127	8	2 x 9"
5	Decal, Reflective Checker Tape	265384	1	
6	Decal, Auger Indicator	9005335	1	
7	Decal, Danger, Electrical Lines	9003474	1	
8	Decal, Danger, PTO Cut & Crush	9003475	2	
9	Decal, Warning (No Riders)	9003476	1	
10	Decal, Flow Control Gate	9003477	1	
11	Decal, Danger Just For Kids	9003478	1	
12	Decal, Important (Shear-Bolts)	9003574	1	
13	Decal, Stripe (5 1/4" x 46")	9004035	6	
14	Decal, Stripe with Tail (5 1/4" x 14 1/4")	9004213	4	
15	Decal, Profile Cart	9004288	1	
16	Decal, Unverferth Logo (5 1/4" x 45 3/4")	9004298	4	
17	Decal, FEMA	91605	1	
18	Decal, Flow Control 3" x 38"	92563	1	
19	Decal, Warning, Tongue Drop	94094	1	
20	Decal, 1060	9501817	4	
21	Decal, Danger, Driveshaft Entanglement	95046	3	
22	Decal, Warning, High Pressure	95445	1	
23	Decal, Warning, Pinch Point	95839	1	
24	Decal, Caution, Transport Chain	97575	1	
25	Decal, Warning (Read & Understand)	97961	1	
26	Decal, Important (PTO Engagement)	9008151	1	
27	Decal, CAUTION (Slippery Surface)	95008	1	



9003474



95046



9003475



9003478



95445



94094



97961



9003476



95839



95008



97575



9003477

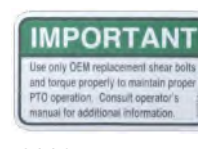

9003574



9008151

Sideboards

Please visit www.unverferth.com/parts/ for the most current parts listing.

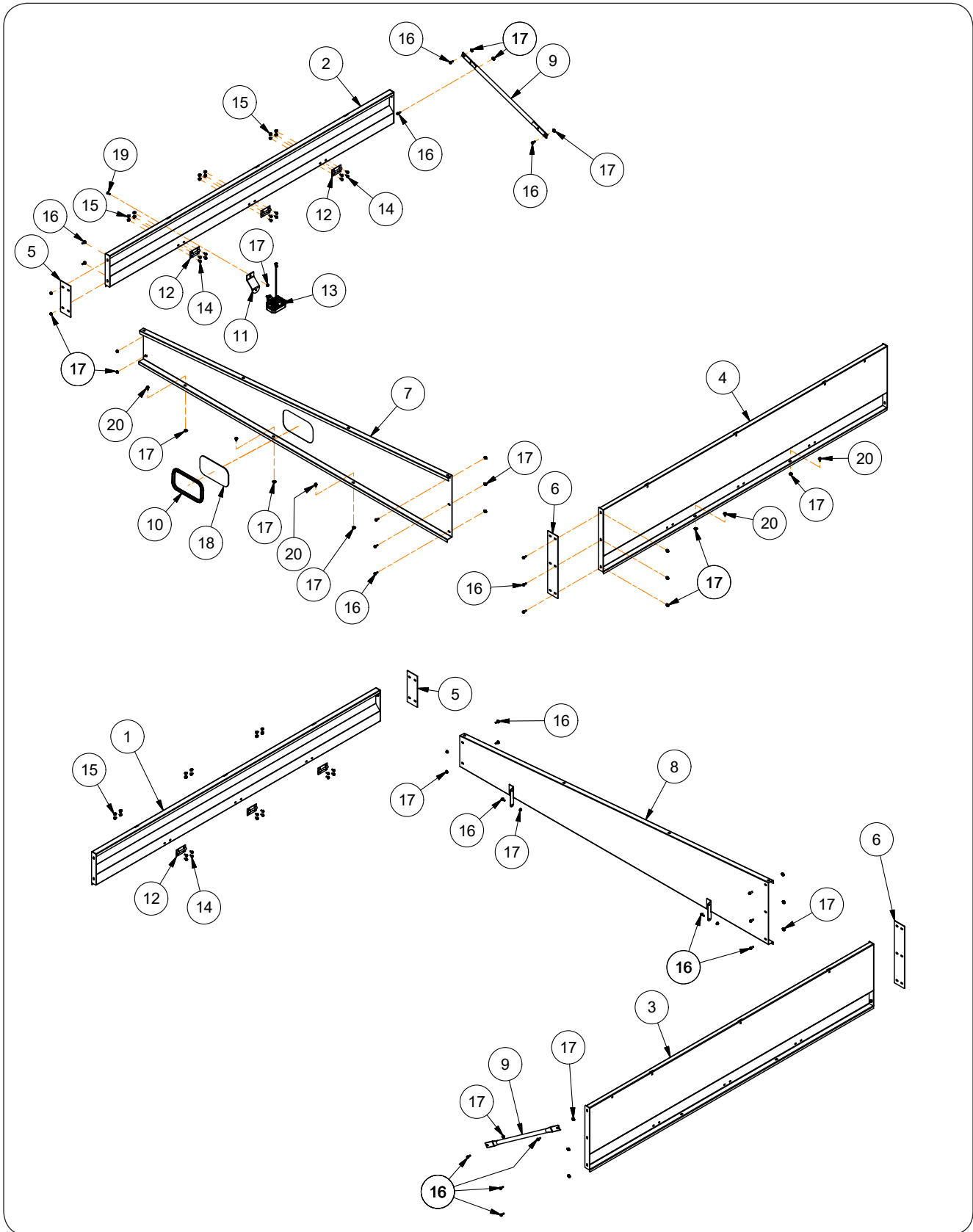

Sideboards

Please visit www.unverferth.com/parts/ for the most current parts listing.

ITEM	DESCRIPTION	PART NO.	QTY	NOTES
1	Sideboard, Rear RH	2007876B	1	
2	Sideboard, Front RH	2007880B	1	
3	Sideboard, Rear LH	2007911B	1	
4	Sideboard, Front LH	2007923B	1	
5	Plate 4 1/2" x 12" with 4 Slots	2007927B	2	
6	Plate 4 1/2" x 24" with 6 Slots	2007928B	2	
7	Hinged Sideboard, Front	2007939B	1	
8	Hinged Sideboard, Rear	2007940B	1	
9	Tube, Angle Brace/Sideboard Support	220032B	2	
10	Window Molding	250431	1	
11	Light Bracket	271574B	1	
12	Hinge	9004626	12	
13	Work Light, LED	9007186	1	
14	Flange Bolt, 5/16" -18UNC x 3/4"	91256	48	
15	Flange Nut, 5/16" -18UNC	91257	48	
16	Flange Screw, 3/8" -16UNC x 1"	91262	39	
17	Flange Nut, 3/8" -16UNC	91263	58	
18	Widow	92403	4	
19	Carriage Bolt, 3/8" -16UNC x 1"	9388-051	1	
20	Flange Screw, 3/8" -16UNC x 3/4"	95585	18	

Electrical

Please visit www.unverferth.com/parts/ for the most current parts listing.

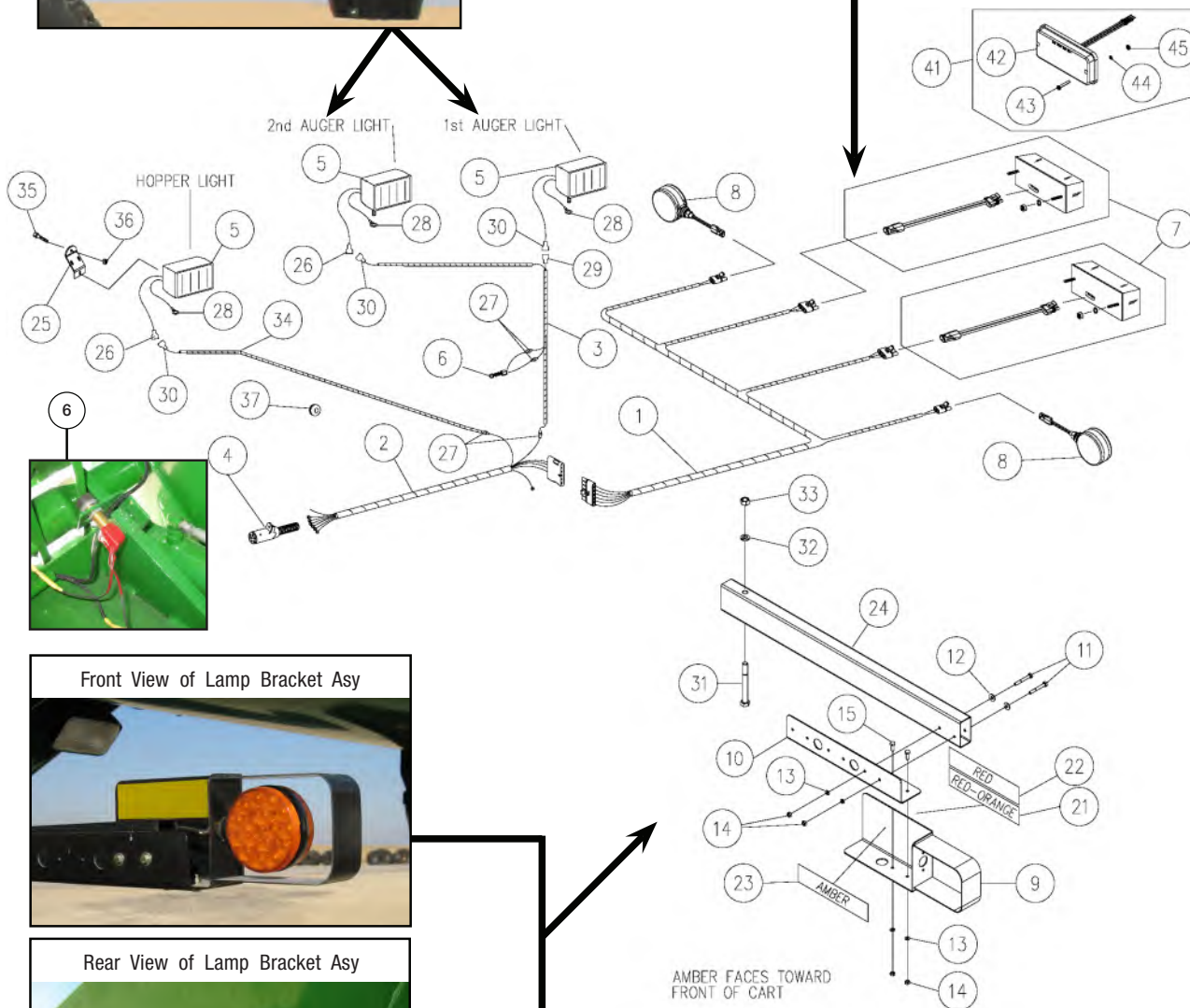
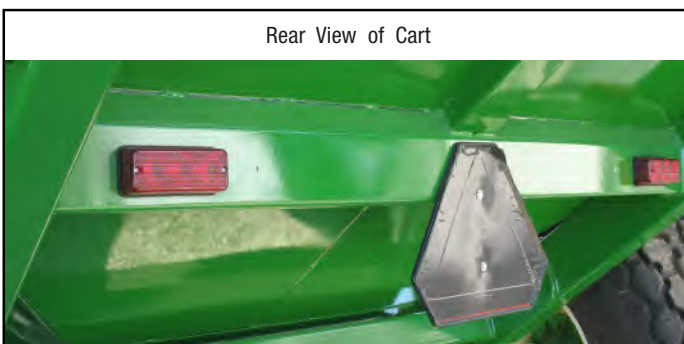
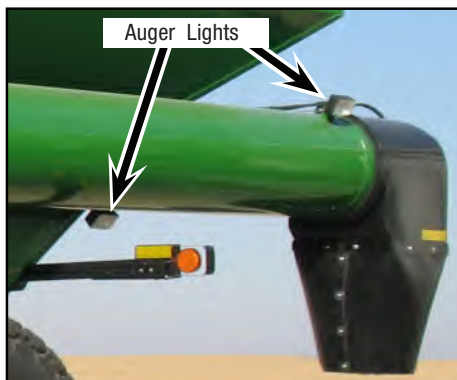

Electrical

Please visit www.unverferth.com/parts/ for the most current parts listing.

ITEM	DESCRIPTION	PART NO.	QTY.	NOTES
1	Wiring Harness, Rear 190"	9003050	1	
2	Wiring Harness, Front 184"	9003981	1	
3	Wiring Harness - Auger Light 297"	9004350	1	
4	Electrical Coupler	92450	1	
5	Auger Light/Flood Lamp	9001155	3	
6	Switch, Momentary	9003046	1	
7	Pan Head Screw #10-32UNF x 2 1/2	9004359	2	
	Wiring Harness - 10"	9005097	1	
	RED LED Light Kit	265642	1	
	Lock Washer #10	9404-013	2	
	Hex Nut #10-32UNF	9830-016	2	
8	LED Light, Amber - Double Face	9005142	2	
	LED Lens Only	9005095	-	
9	LH Light Bracket Weldment (Shown)	252302B	1	
	RH Light Bracket Weldment	252301B	1	
10	LH Plate	251406B	1	
	RH Plate	251407B	1	
11	Capscrew, 1/4-20 UNC x 2	9390-009	4	
12	Flat Washer, 1/4	9405-064	8	
13	Lock Washer, 1/2	9404-017	8	
14	Hex Nut, 1/4-20UNC	9394-002	8	
15	Capscrew, 1/4-20UNC x 3/4	9390-003	4	
21	Fluorescent Strip, Red-Orange	9003125	2	2 x 9"
22	Red Reflector	9003126	2	2 x 9"
23	Amber Reflector	9003127	7	2 x 9"
24	Tube, Lamp Extension	280370B	2	
25	Plate, Lamp Mount	271574B	1	
26	Connector, Female	TAB65407	2	
27	Connector, Butt	9000166	4	
28	Connector, 1/2" Eyelet	9002127	3	
29	Connector, T-Tap	9004139	1	
30	Connector, Male Spade	9004140	3	
31	Capscrew, 1/2-13UNCx4	9390-112	2	
32	Lock Washer, 1/2	9404-025	2	
33	Nut, 1/2-13UNC	9394-010	2	
34	Harness, Inside 380"	9003983	1	
35	Carriage Bolt, 3/8-16UNC x 1	9388-051	1	
36	Locknut/Top, 3/8-16UNC	9003396	1	
37	Rubber Grommet	9001005	1	
38	Wiring Harness - 24"	9005600	Opt	Required when adjusting axle (Not Shown)
39	Cable Tie, 6"	9000106	7	Not Shown
40	Cable Tie, 15 1/2"	9000107	2	Not Shown
41	Red LED Replacement Light Kit	232170	2	Replaces one light Includes Items 42, 43, 44, 45
42	Red Light- Tail/Turn (LED)	9006282	2	
43	Pan Head Machine Screw #10-32UNF x 1 1/4	903172-350	4	
44	Split Lock Washer, #10	9404-013	4	
45	Hex Nut #10-32 Grade 2	9830-016	4	

Drive Components

Please visit www.unverferth.com/parts/ for the most current parts listing.

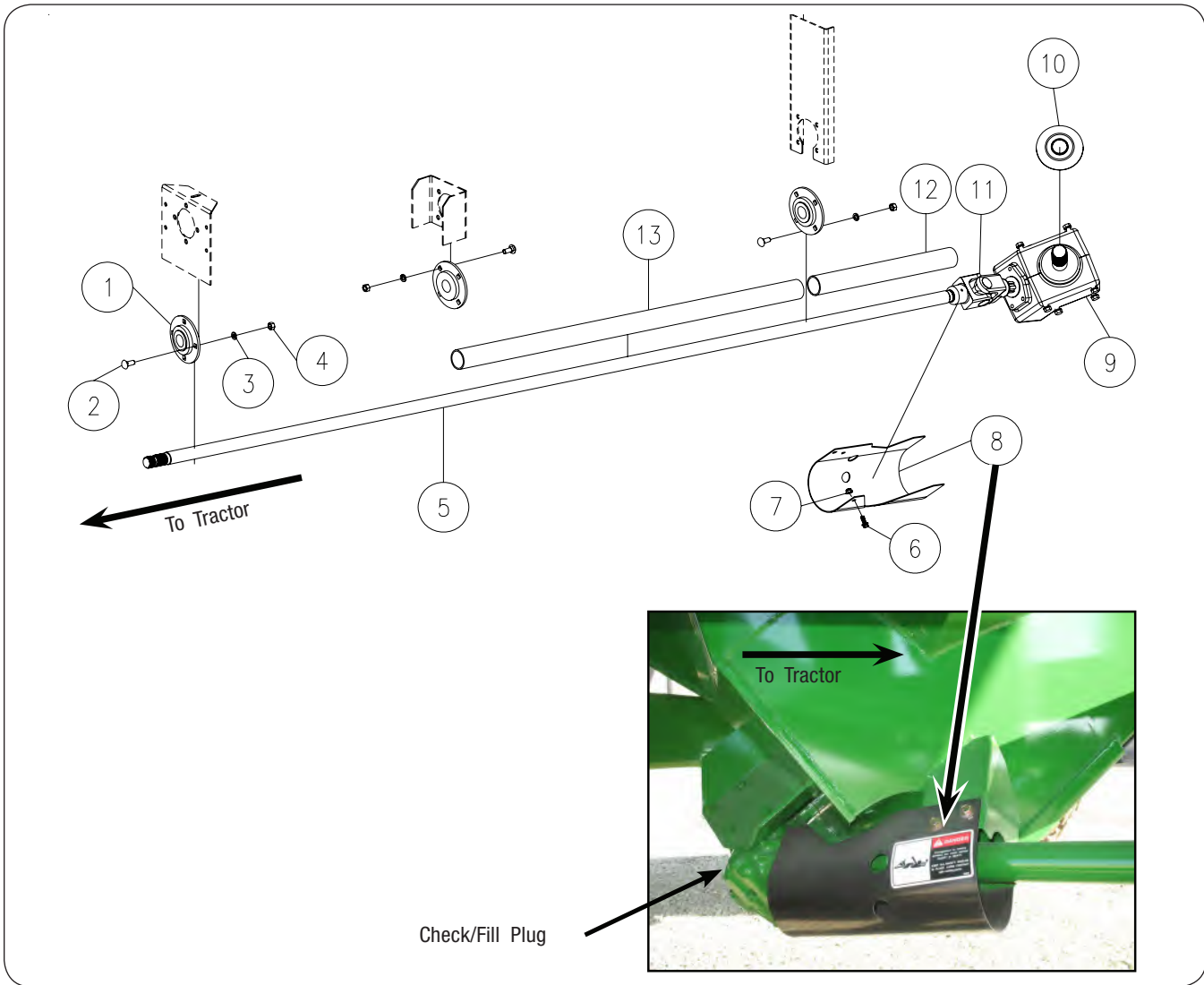

Drive Components

Please visit www.unverferth.com/parts/ for the most current parts listing.

ITEM	DESCRIPTION	PART NO.	QTY.	NOTES
1	1 1/2 Flangette Bearing	9003920	3	
2	Carriage Bolt 1/2-13 x 1 1/4	9388-103	12	
3	Lock Washer 1/2	9404-025	12	
4	Hex Nut 1/2-13UNC	9394-010	12	
5	Driveshaft 1 1/2 x 125.5	280140	1	1 3/8-21 Splined
6	Screw/Large Flange 3/8-16 x 1	91262	3	
7	Locknut 3/8-16UNC	9003396	3	Welded to Cover
8	U-Joint Cover	280160B	1	
9	Gearbox	9002812	1	Refer to "45 Degree Gear Box" in this Section for Parts Listing
10	Gearbox Dust Cover	92805B	1	
11	U-Joint Assy	95012	1	Refer to "Driveline U-Joint Assembly" in this Section for Parts Listing
12	Tube 2" SCH 40 x 21"	280158	1	
13	Tube 2" SCH 40 x 52"	280157	1	

Auger Components

Please visit www.unverferth.com/parts/ for the most current parts listing.

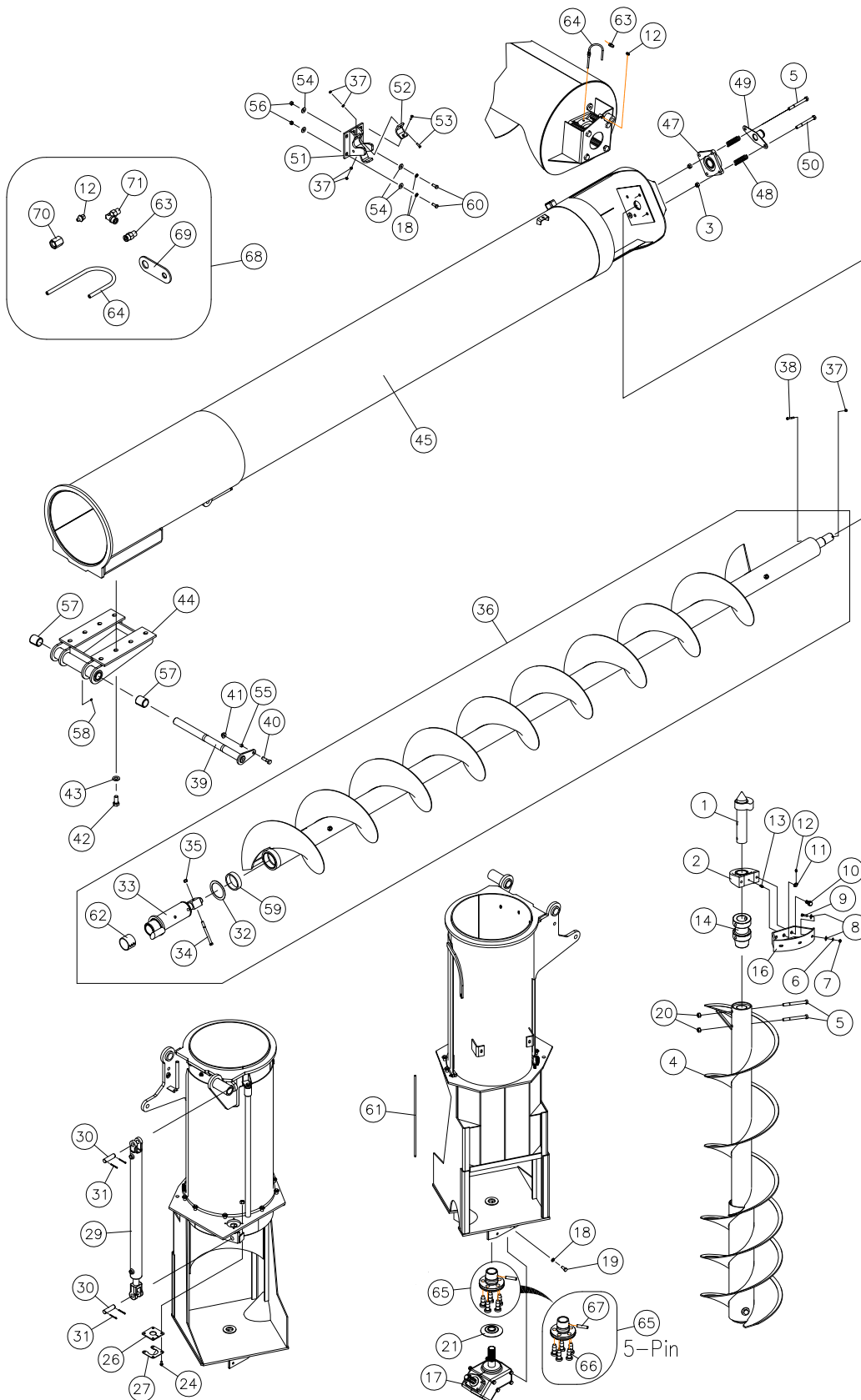

Auger Components

Please visit www.unverferth.com/parts/ for the most current parts listing.

ITEM	DESCRIPTION	PART NO.	QTY	NOTES
1	Drive Dog Weldment	280568	1	
2	Pillow Block Bearing 2 1/2 Bore	9004731	1	
3	Locknut 5/8-11UNC	9801	4	
4	Lower Auger Kit	281578-SER	1	Includes Items 14, 22 & 25
5	Capscrew 5/8-11UNC x 6	9390-136	4	Grade 5
6	Lock Washer 3/8	9404-021	3	
7	Hex Nut 3/8-16UNC	9394-006	3	Grade 5
8	Flat Washer 3/8	9405-076	6	
9	Capscrew 3/8-16UNC x 1 1/4	9390-056	3	Grade 5
10	Capscrew 5/8-11UNC x 1 1/2	9390-122	2	Grade 5
11	90° Elbow 1/8 NPTF Female x 1/8 NPTF Female	9004764	1	
12	Grease Zerk 1/8 NPT	93426	1	
13	Nipple 1/8 NPTF Male x 1/8 NPTF Male Hex Pipe	9004765	1	
14	Adapter 4.75 Dia. x 8	281209	1	
16	Hanger Bearing Weldment	281502B	1	
17	Gearbox 45°	9002812	1	
18	Lock Washer 1/2	9404-025	12	
19	Capscrew 1/2-13UNC x 1 1/2	9390-100	8	Grade 5
20	Locknut 5/8-11UNC	9801	2	Grade 5
21	Dust Cover for Gearbox	92805	1	
24	Screw/Large Flange 3/8-16UNC x 1	91262	4	Grade 5
25	Auger Height Pin 1" Dia. x 2" Long	250004	1	
26	Rubber Gasket 1/4 x 4 x 4	268217	1	
27	Cover Plate	268218	1	
29	Cylinder 2 1/2 x 36 (3000 PSI)	9005363	1	
30	Pin 1" Dia. x 3 1/2	804572	2	
31	Cotter Pin 3/16" Dia. x 2	9391-046	4	
32	Self-Lubricating Thrust Washer 5.25" Dia.	9004878	1	
33	Soft Start Kit	281682	1	
34	Capscrew 1/2-13UNC x 6	9390-115	1	Grade 5
35	Locknut 1/2-13UNC	9800	1	
36	Upper Auger Replacement Kit =Black=	281262	1	Includes Items 32, 33, 34, 35 & 59
37	Hex Nut 5/16-18UNC	9394-004	5	Grade 5
38	Capscrew 5/16-18UNC x 2 1/2	9390-036	1	Grade 5
39	Shaft & Plate Weldment	268946	1	
40	Capscrew 5/8-11UNC x 2 1/2	9390-126	1	Grade 5
41	Locknut 5/8-11UNC	9003398	1	
42	Capscrew 7/8-9UNC x 2	9390-164	8	Grade 5
43	Flat Washer 7/8 Nom.	97041	8	
44	Auger Pivot Assembly =Green=	268494G	1	Includes Items 57 & 58
	Auger Pivot Assembly =Red=	268494R		
45	Upper Auger Tube Weldment =Green=	281520G	1	
	Upper Auger Tube Weldment =Red=	281520R		
	Wear Ring Pad - Required when using 281520G/R to adapt the seal on the hood	268282	1	

(Continued on next page)

Unverferth 1060 — Parts

Auger Components (continued)

Please visit www.unverferth.com/parts/ for the most current parts listing.

ITEM	DESCRIPTION	PART NO.	QTY	NOTES
47	Flanged Bearing 2" Dia. With Grease Zerk	9002492	1	
	Grease Zerk 1/4-28	91160	1	
48	Compression Spring 1.207 OD	9004899	4	
49	Hood Pivot Pin Weldment	268573	1	
50	Capscrew 5/8-11UNC x 6 1/2	9390-137	2	
51	Auger Rest Weldment =Green=	268646G	1	
	Auger Rest Weldment =Red=	268646R		
52	Rubber Stop Pad 3/8 x 2 x 5	9004263	1	
53	Flat Head 5/16-18UNC x 1 1/4 Machine Screw	9400-102	2	
54	Flat Washer 1/2	9405-088	4	
55	Spacer Bushing 1 1/2 OD x 3/4 ID x 1/2	268896	1	
56	Hex Nut 1/2-13UNC	9394-010	4	Grade 5
57	Bushing 2.25OD x 1.75 ID x 2 1/2	9004980	2	
58	Grease Zerk	91160	1	
59	Self-Lubricating Bushing	9004877	1	
60	Capscrew 1/2-13UNC x 1 3/4	9390-102	4	Grade 5
61	Indicator Pipe =Black=	280606B	1	
62	Split Bushing 2 3/4 Dia.	9003230	1	
63	Quicklinc Fitting	9005073	2	
64	Tube, Greased Nylon 1/4" OD	9005074	1	
65	Drive Plate Assembly - 5 Pin	286436	1	For 5 Drive Pins Inside Flighting Pipe
66	Drive Pin, 0.763 Dia. x 2	9007000	5	
67	Spiral Pin, 1/2 Dia. x 2 1/4	902614-236	1	
68	Grease Hose Kit = Black	281849B	1	Serial Number B32920099 and Lower Includes Items: 12, 63, 64
69	Bracket for Grease Hose	281851B	1	
70	Pipe Coupling, 1/8NPT Female	9003949	1	
71	Quicklinc Fitting, 1/4" Tube x 1/8NPT 90° SVL	9005072	1	

Auger Fold Indicator

Please visit www.unverferth.com/parts/ for the most current parts listing.

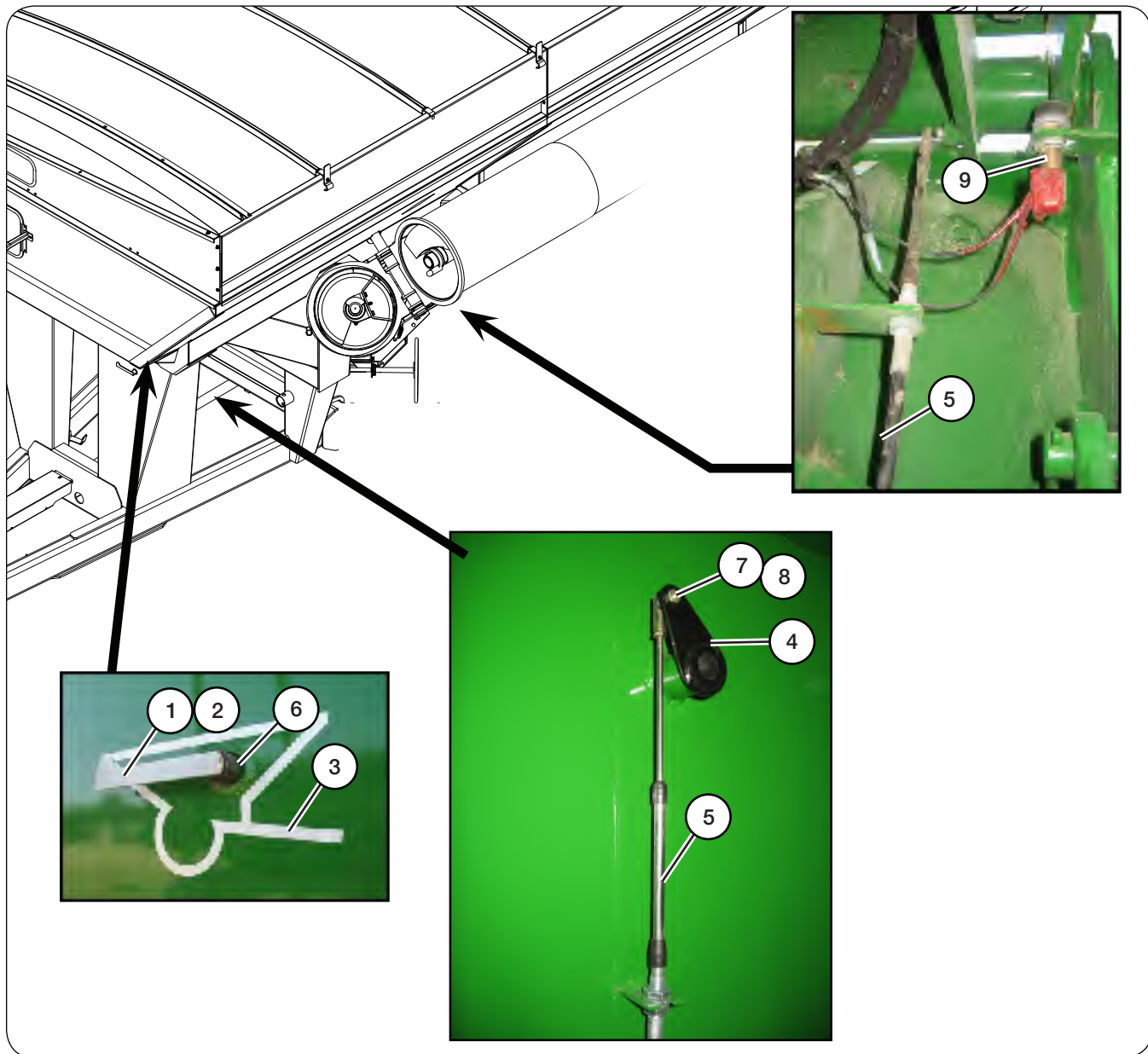

ITEM	DESCRIPTION	PART NO.	QTY.	NOTES
1	Auger Indicator Weldment	280575	1	
2	Decal, Auger Indicator	9005335	1	
3	Decal, Cart Profile	9004288	1	
4	Indicator Retainer Weldment	268671B	1	
5	Cable, Push/Pull 180"	9005382	1	
6	Set Screw 5/16-18UNC x 3/8	9399-071	1	
7	Hex Nut #10-32	9830-016	1	Grade 2
8	Lock Washer #10	9404-013	1	
9	Momentary Switch	9003046	1	

Cleanout Door Assembly

Please visit www.unverferth.com/parts/ for the most current parts listing.

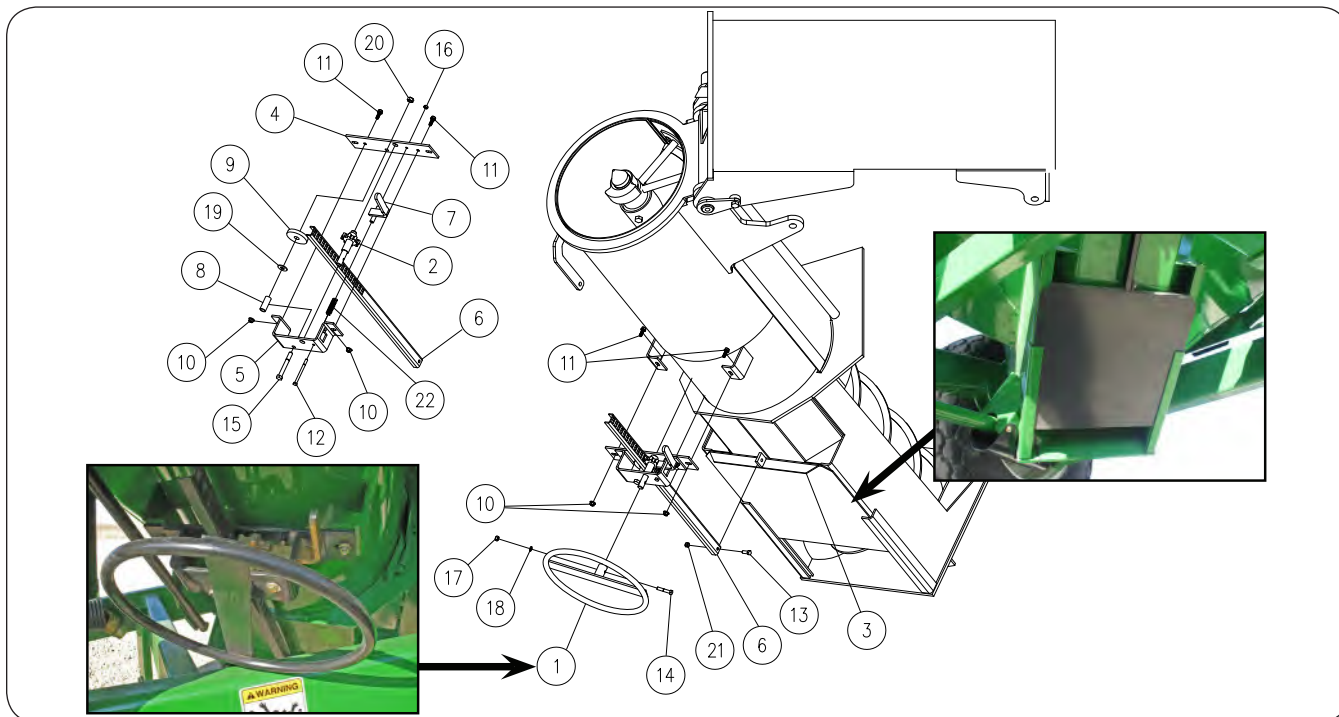

ITEM	DESCRIPTION	PART NO.	QTY.	NOTES
1	Door Wheel Weldment	220060B	1	
2	Shaft & Gear Weldment	281062	1	
3	Door Weldment	281015B	1	
4	Plate, Back Door Lift	281059B	1	
5	Plate, Front Door Lift	281060B	1	
6	Rack	281105B	1	
7	Handle Weldment, Door	281109	1	
8	Bushing, Spacer	281145B	1	
9	Roller, Plastic	222118	1	
10	Locknut, 3/8-16UNC Auto.	9003396	4	
11	Carriage Bolt, 3/8-16UNC x 1	9388-051	4	
12	Capscrew, 5/16-18UNC x 4-1/2	9390-043	1	
13	Flange Head Screw, 3/8-16x1	91262	1	
14	Capscrew, 3/8-16UNC x 2	9390-059	1	
15	Capscrew, 1/2-13UNC x 4	9390-111	1	
16	Lock Nut, 5/16-18UNC	9807	1	
17	Hex Nut, 3/8-16UNC	9394-006	1	
18	Flat Washer 5-16	9405-070	1	
19	Lock Washer, 3/8	9404-021	1	
20	Flat Washer, 1/2	9405-088	1	
21	Lock Nut, 1/2-13UNC	94981	1	
22	Lock Nut/Top, 3/8-16UNC	9928	1	
23	Spring, Stop Pin	TA510035	1	

Flow Door Seals

Please visit www.unverferth.com/parts/ for the most current parts listing.

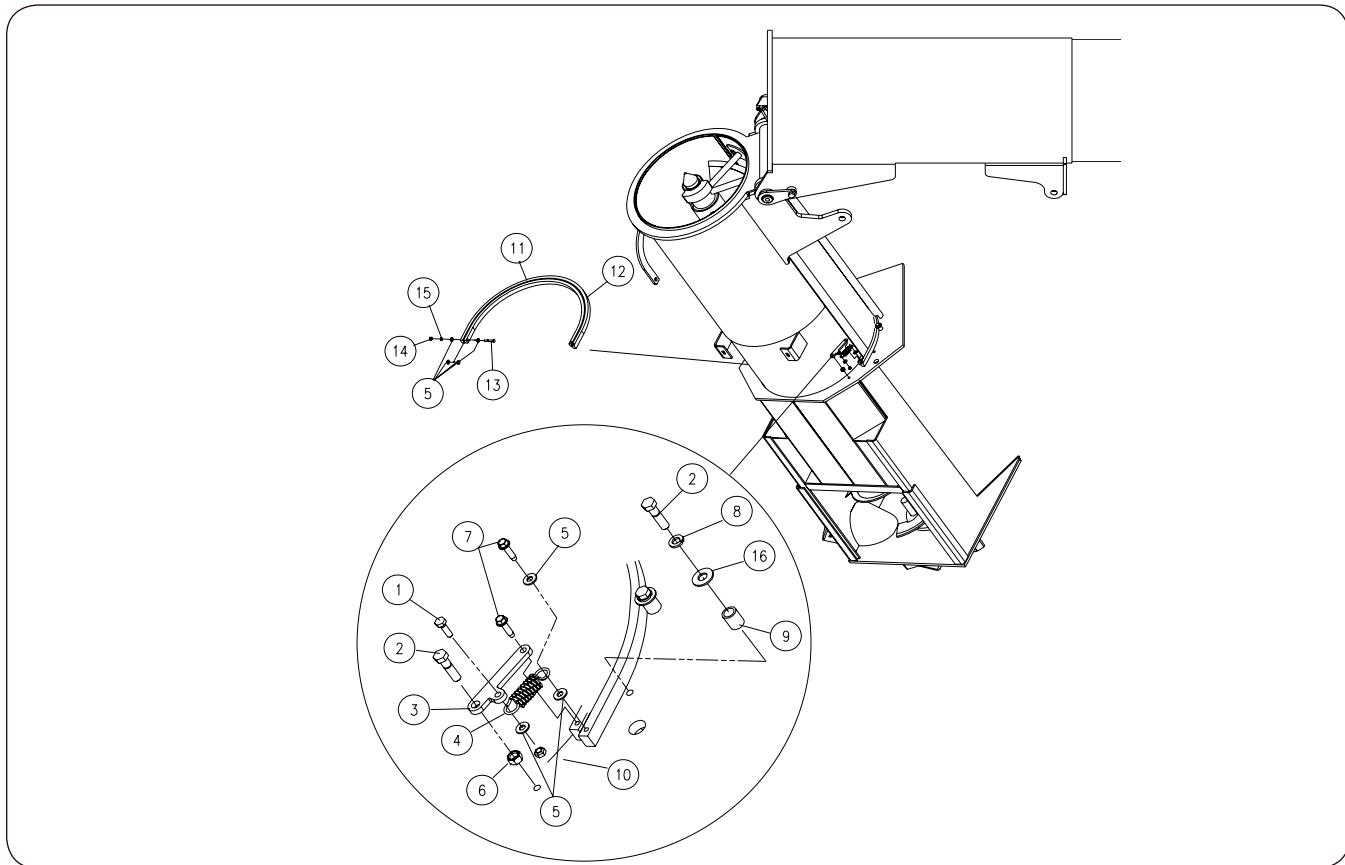

ITEM	DESCRIPTION	PART NO.	QTY.	NOTES
1	Capscrew, 1/4-20UNCx7/8 G5	9390-004	1	
2	Capscrew, 3/8-16UNCx1 1/2 G5	9390-057	7	
3	Spring Bracket =Green=	281258G	1	
	Spring Bracket =Red=	281258R		
4	Spring	9004375	1	
5	Flat Washer 1/4	9405-062	7	
6	Hex Nut, 3/8-16UNC G5	9394-006	1	
7	Screw, 1/4-20UNCx1 (Self-Threading)	9004355	2	
8	Lock Washer, 3/8	9404-021	6	
9	Spacer Bushing =Green=	281257G	6	
	Spacer Bushing =Red=	281257R		
10	Lock Nut, 1/4-20UNC	9936	1	
11	Seal - Poly	281256	1	
12	Seal - Poly	281255	1	
13	Capscrew, 1/4-20UNCx1 3/4 G5	9390-008	1	
14	Hex Nut, 1/4-20UNC G5	9394-002	1	
15	Lock Washer, 1/4	9404-017	1	
16	Fender Washer, 3/8	9004537	6	

Cylinders — 3" x 24" (Auger Fold)

Please visit www.unverferth.com/parts/ for the most current parts listing.

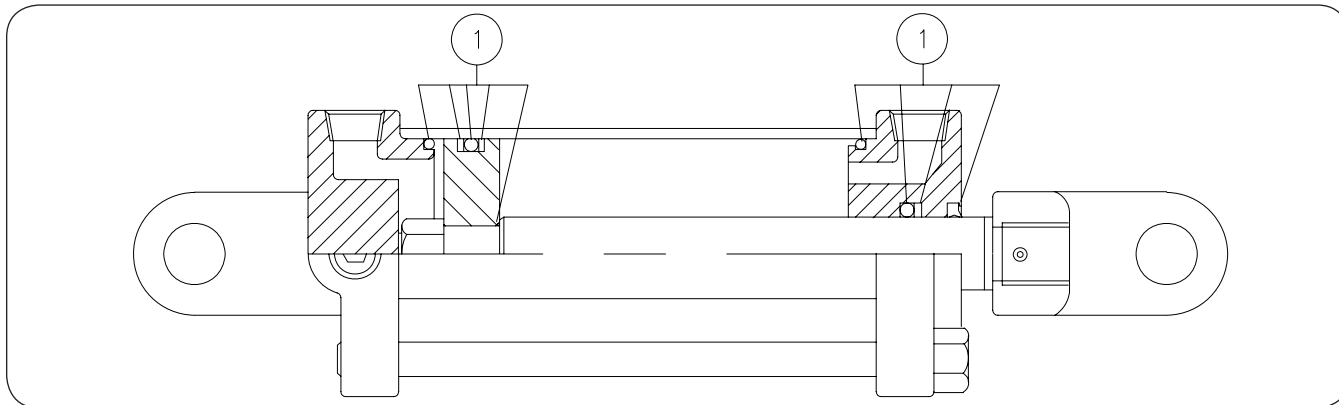

ITEM	DESCRIPTION	PART NO.	QTY.	NOTES
	Cylinder Kit	280920	1	
1	Seal Kit	9004382	1	

Cylinders — 2 1/2" x 36" (Flow Door)

ITEM	DESCRIPTION	PART NO.	QTY.	NOTES
	Cylinder, Complete	9005363	1	
1	Seal Kit	9005409	1	

Cylinders — 1 1/2" x 8" (Discharge Spout)

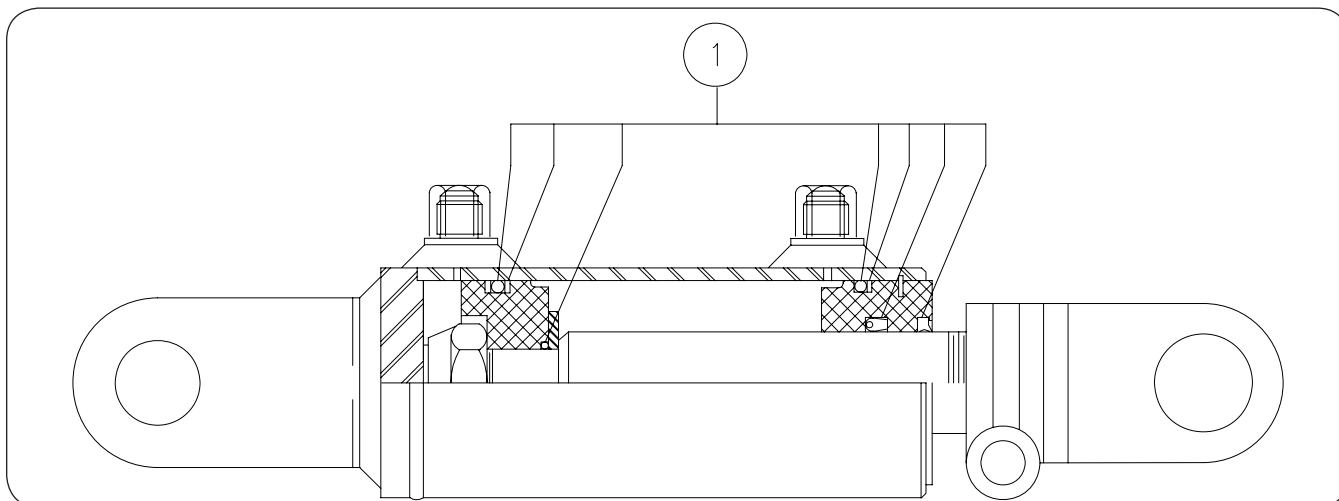

ITEM	DESCRIPTION	PART NO.	QTY.	NOTES
	Cylinder, Complete	9005135	1	
1	Seal Kit	9005419	1	

Notes

Please visit www.unverferth.com/parts/ for the most current parts listing.

Hydraulics

Please visit www.unverferth.com/parts/ for the most current parts listing.

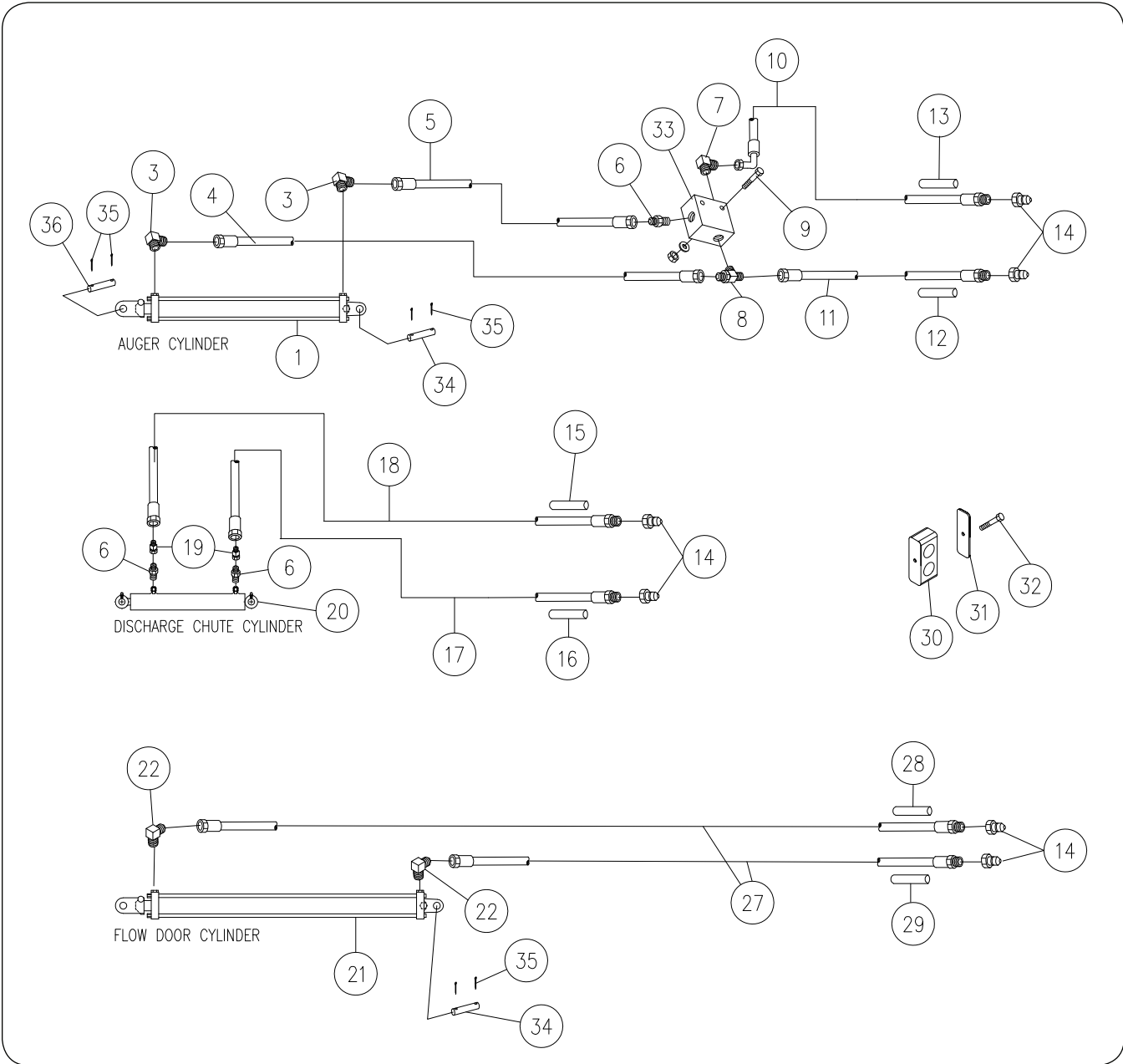

Unverferth 1060 — Parts

Hydraulics

Please visit www.unverferth.com/parts/ for the most current parts listing.

ITEM	DESCRIPTION	PART NO.	QTY	NOTES
1	Hydraulic Cylinder, 3 x 22 - 3000 PSI	9004730	1	
	Fold Cylinder 3 x 22 Seal Kit	9003772	1	
3	90° Elbow (9/16-18 JIC Male x 9/16-18 O-Ring Male)	9004379	2	w/.055 Restrictor
4	Hose 1/4 x 94 (9/16-18 JIC Female x 9/16-18 JIC Female)	9003275	1	
5	Hose 1/4 x 75 (9/16-18 JIC Female x 9/16-18 JIC Female)	9003343	1	
6	Adapter (9/16-18 JIC Male x 9/16-18 O-Ring Male)	9001495	3	
7	90° Elbow (9/16-18 JIC Male x 9/16-18 O-Ring Male)	97445	1	
8	Tee (9/16-18 JIC Male x 9/16-18 O-Ring Male x 9/16-18 JIC Male)	9001710	1	
9	Capscrew 5/16-18UNC x 1 3/4	9390-033	2	Grade 5
	Lock Washer 5/16	9404-019	2	
	Hex Nut 5/16-18UNC	9394-004	2	
10	Hose 1/4 x 238 (90° Elbow 9/16-18 JIC Female x 3/4-16 O-Ring Male)	9003144	1	
11	Hose 1/4 x 239 (9/16-18 JIC Female x 3/4-16 O-Ring Male)	9003210	1	
12	Sleeve, Hose Marker (GREEN, Auger Lower)	9003998	1	
13	Sleeve, Hose Marker (GREEN, Auger Raise)	9003997	1	
14	Male Coupler 3/4-16 Female O-Ring	91383	6	
15	Sleeve, Hose Marker (YELLOW, Spout In)	9004000	1	
16	Sleeve, Hose Marker (YELLOW, Spout Out)	9003999	1	
17	Hose 1/4 x 553 (90° Elbow 9/16-18 JIC Female x 3/4-16 O-Ring Male)	9502174	2	
18				
19	Adapter (9/16-18 JIC Female x 9/16-18 JIC Male)	95193	2	w/.030 Restrictor
20	Directional Spout Cylinder 1 1/2 x 8 Seal Kit	9005419	1	
21	Flow Door Cylinder 2 1/2 x 36 Seal Kit	9005409	1	
22	90° Elbow (9/16-18 JIC Female x 3/4-16 O-Ring Male)	9874	2	
27	Hose 1/4 x 295 (9/16-18 JIC Female x 3/4-16 O-Ring Male)	9004121	2	
28	Sleeve, Hose Marker (RED, Flow Door Open)	9003995	1	
29	Sleeve, Hose Marker (RED, Flow Door Close)	9003996	1	
30	Clamp Pair	9003816	6	
31	Top Plate	9003814	6	
32	Capscrew 5/16-18UNC x 1 1/4	9390-031	6	Grade 5
33	Pilot Operated Check Valve Block	9003990	1	
34	Pin 1" Dia. x 3 1/2 (For Auger & Door Cylinders)	804572	3	
35	Cotter Pin 3/16" Dia. x 2	9391-046	8	
36	Pin 1" Dia. x 4 (For Rod Eye - Auger Cylinder)	250104	1	
37	Cylinder 1 1/2 x 4	9003789	1	NOT SHOWN - See Directional Spout

Directional Spout

Please visit www.unverferth.com/parts/ for the most current parts listing.

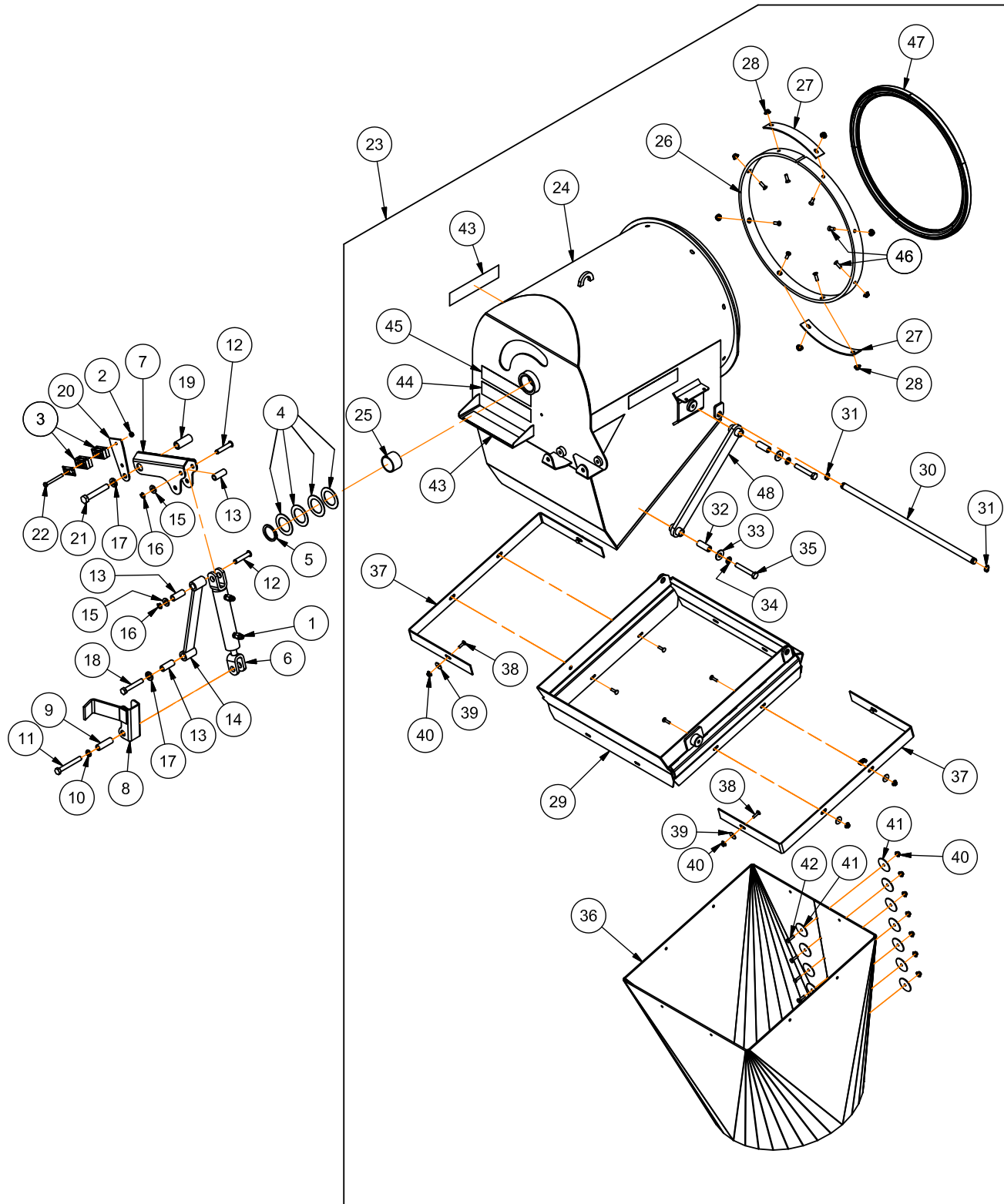

Unverferth 1060 — Parts

Directional Spout

Please visit www.unverferth.com/parts/ for the most current parts listing.

ITEM	DESCRIPTION	PART NO.	QTY.	NOTES
1	Adapter 9/16-18 JIC Female x 9/16-18 JIC Male	95193	3	with 0.030 Restrictor
2	Hex Nut 5/16"-18UNC	9394-004	4	
3	Poly Clamp Pair	9003816	10	
4	Flat Washer 2"	93974	4	
5	Retaining Ring 2"	91178	1	
6	Cylinder 1 1/2 x 4	9003789	1	
	Seal Kit	9005419	1	
7	Linkage Bracket	284691B	1	
8	Cylinder Stop Weldment	287648B	1	
9	Sleeve Bushing 0.75" OD x 0.532" ID x 2.438"	272571	1	
10	Lock Washer 1/2"	9404-025	1	
11	Capscrew 1/2"-13UNC x 4" G5	9390-111	1	
12	Pin Weldment 1/2" Dia. x 2 21/32"	285219	2	
13	Sleeve Bushing 0.75" OD x 0.532" ID x 1.938"	285290	3	
14	Linkage Weldment	284699B	1	
15	Flat Washer 1/2" SAE	9405-086	2	
16	Snap Ring 1/2"	9005687	2	
17	Lock Washer 5/8"	9404-030	2	
18	Capscrew 1/2"-13UNC x 3 1/4" G5	9390-108	1	
19	Sleeve Bushing 1" OD x 0.640" ID x 2.438"	272619	1	
20	Hose Bracket	272620B	1	
21	Capscrew 5/8"-11UNC x 4" G5	9390-132	1	
22	Capscrew 5/16"-18UNC x 3" G5	9390-038	2	
23	Spout Assembly	2007607B	1	Includes Items 24-48
24	Spout Weldment	287636B	1	
25	Self Lubricating Bushing 2.25 OD x 2.00 ID x 1.5	9005085	1	
26	Wear Ring Pad 3/8" x 1 1/2" x 65 1/16"	268282	1	
27	Hood Shim Plate	268972B	2	
28	Hex Nut/Large Flange 5/16-18UNC	91257	8	
29	Spout Weldment	287630B	1	
30	Pivot Shaft 3/4" Dia. x 24 5/16"	272596	1	
31	Snap Ring 3/4"	9003810	2	
32	Sleeve Bushing 0.75" OD x 0.532" ID x 1.938"	285290	2	
33	Flat Washer 1/2" USS	9405-088	2	
34	Lock Washer 1/2"	9404-025	2	
35	Capscrew 1/2"-13UNC x 3 1/4" G5	9390-108	2	
36	Rubber Chute	9007250	1	
37	Chute Strap	286469B	2	
38	Carriage Bolt 1/4"-20UNC x 1" G5	9388-003	8	
39	Fender/Flat Washer 1/4"	9405-066	8	
40	Hex Nut/Large Flange 1/4-20UNC	97189	15	
41	Fender Washer 5/16"	94763	14	
42	Capscrew 1/4"-20UNC x 1" G5	9390-005	7	Grade 5
43	Reflector AMBER	9003127	4	
44	Decal, Fluorescent Orange	9003125	1	
45	Reflector RED	9003126	1	
46	Machine Screw Phillips 5/16"-18UNC x 1" G5	903171-660	8	
47	Trim Lock/Flap Seal	9008122	AR	Specify in Feet (Approx 6' Required)
48	Link Weldment	2007601B	1	

PTO Assembly Shearbolt Clutch

Please visit www.unverferth.com/parts/ for the most current parts listing.

1 3/4-20 Spline Shown

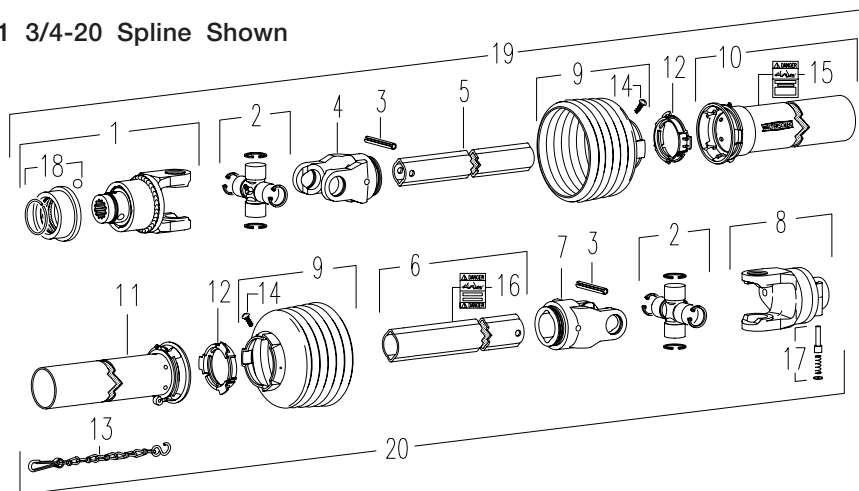

Optional 1 3/8-21 Spline Shown

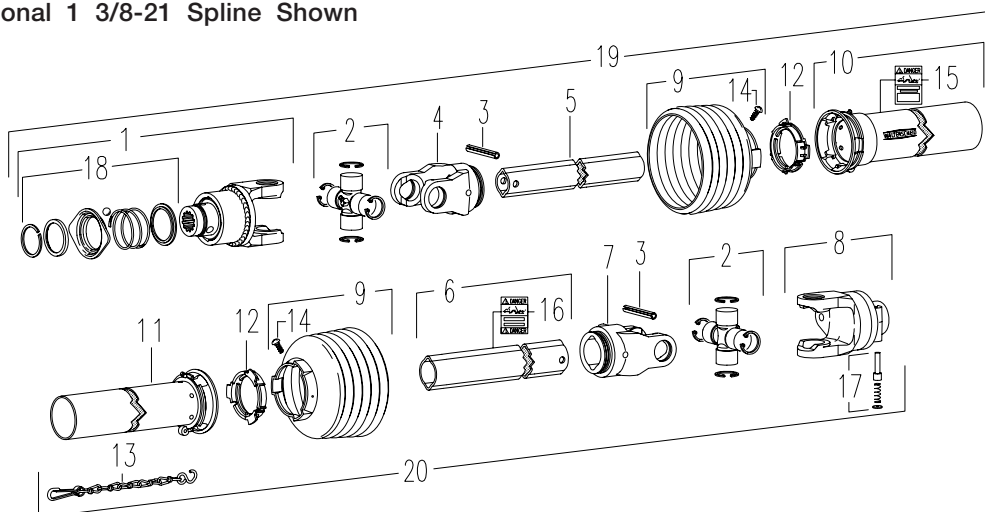

PTO Assembly Shearbolt Clutch

Please visit www.unverferth.com/parts/ for the most current parts listing.

ITEM	DESCRIPTION	PART NO.	QTY	NOTES
	PTO Assembly Complete	9004767	1	1 3/4-20 Spline
	PTO Assembly Complete	9004766	1	1 3/8-21 Spline (optional)
1	End Yoke / Overrunning Clutch	9004778	1	1 3/4-20 Spline
	End Yoke / Overrunning Clutch	9004777	1	1 3/8-21 Spline (Optional)
2	Cross & Bearing Kit	93857	2	
3	Spring Pin	93859	2	
4	Front Inboard Yoke	93858	1	
5	Inner Profile	9004274	1	
6	Outer Profile	94837	1	
7	Rear Inboard Yoke	93862	1	
8	Shear Clutch Complete	9004170	1	1 3/8-21 Spline
9	Shield Cone, Black 6-Rib	93863	2	
10	Outer Shield Tube w/Cap	94839	1	
11	Inner Shield Tube w/Cap	94840	1	
12	Bearing Ring	92373	2	
13	Safety Chain	92374	1	
14	Screw	92372	2	
15	Decal, "Danger / Out"	92377	1	
16	Decal, "Danger / Inn"	95046	1	
17	Quick Disconnect Kit for Shear Clutch	92362	1	
18	Quick Disconnect Kit for Overrunning Clutch	93856	1	1 3/4-20 Spline
	Quick Disconnect Kit for Clutch	92393	1	1 3/8-21 Spline (Optional)
19	Front Half PTO for Shear Clutch	9004771	1	1 3/4-20 Spline
	Front Half PTO for Shear Clutch	9004770	1	1 3/8-21 Spline (Optional)
20	Rear Half PTO / Shear Clutch	9004136	1	

PTO Assembly Friction Clutch

Please visit www.unverferth.com/parts/ for the most current parts listing.

1 3/4-20 Spline Shown

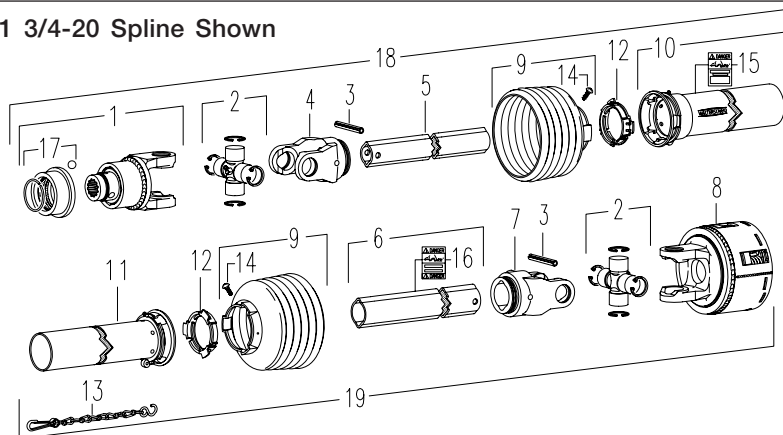

Optional 1 3/8-21 Spline Shown

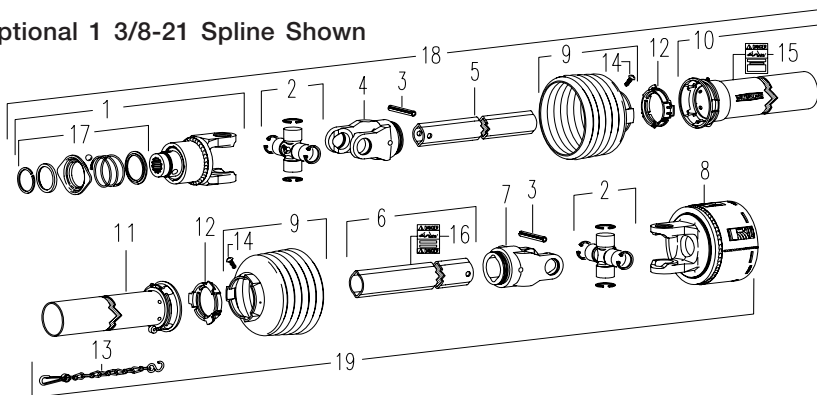

ITEM	DESCRIPTION	PART NO.	QTY	NOTES
	PTO Assembly Complete	9004769	1	1 3/4-20 Spline
	PTO Assembly Complete	9004768	1	1 3/8-21 Spline (optional)
1	End Yoke / Overrunning Clutch	9004778	1	1 3/4-20 Spline
	End Yoke / Overrunning Clutch	9004777	1	1 3/8-21 Spline (Optional)
2	Cross & Bearing Kit	93857	2	
3	Spring Pin	93859	2	
4	Front Inboard Yoke	93858	1	
5	Inner Profile	9004274	1	
6	Outer Profile	94837	1	
7	Rear Inboard Yoke	93862	1	
8	Friction Clutch Complete	9004275	1	1 3/8-21 Spline
9	Shield Cone, Black 6-Rib	93863	2	
10	Outer Shield Tube w/Cap	94839	1	
11	Inner Shield Tube w/Cap	94840	1	
12	Bearing Ring	92373	2	
13	Safety Chain	92374	1	
14	Screw	92372	2	
15	Decal, "Danger / Out"	92377	1	
16	Decal, "Danger / Inn"	95046	1	
17	Quick Disconnect Kit for Overrunning Clutch	93856	1	1 3/4-20 Spline (ONLY)
	Quick Disconnect Kit for Clutch	92393	1	1 3/8-21 Spline (ALL)
18	Front Half PTO	9004771	1	1 3/4-20 Spline
	Front Half PTO	9004770	1	1 3/8-21 Spline (Optional)
19	Rear Half PTO / Friction	9004212	1	

Friction Clutch Assembly

Please visit www.unverferth.com/parts/ for the most current parts listing.

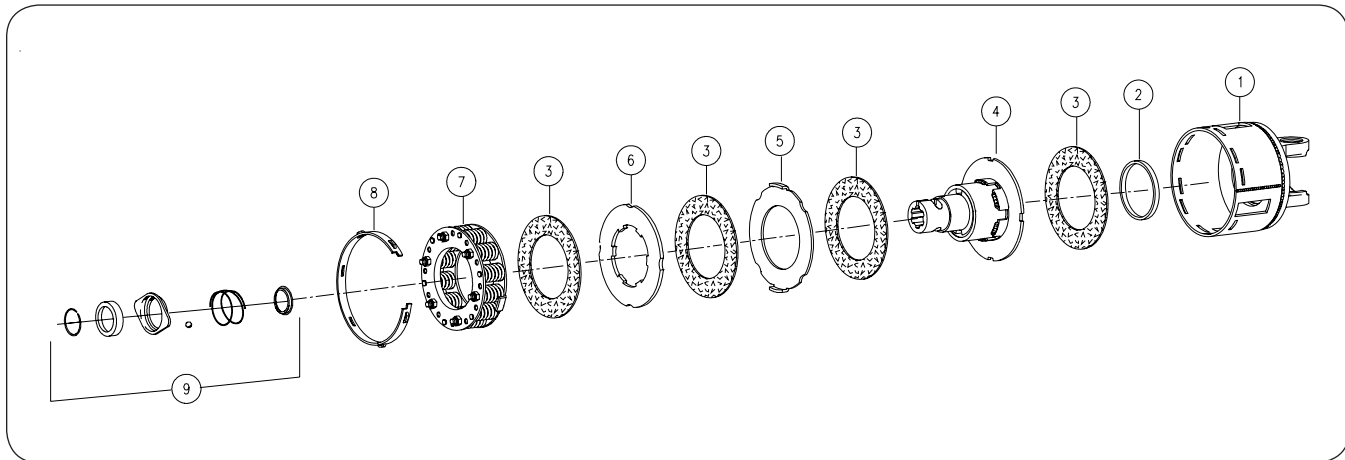

NOTE: The clutch is preset at the factory and should not require adjustment. See Section 1 for specific clutch information.

ITEM	DESCRIPTION	PART NO.	QTY	NOTES
	Complete Clutch	9004275	1	
1	Clutch Housing	9004276	1	
2	Ring	9002770	1	
3	Friction Disk	9002771	4	
4	Hub	9004277	1	
5	Drive Plate	9002780	1	
6	Drive Plate	9002781	1	
7	Spring Pack	9002782	1	
8	Setting Ring	9002783	1	
9	Quick Connect Flange Kit	92393	1	

Shear Bolt Clutch

Please visit www.unverferth.com/parts/ for the most current parts listing.

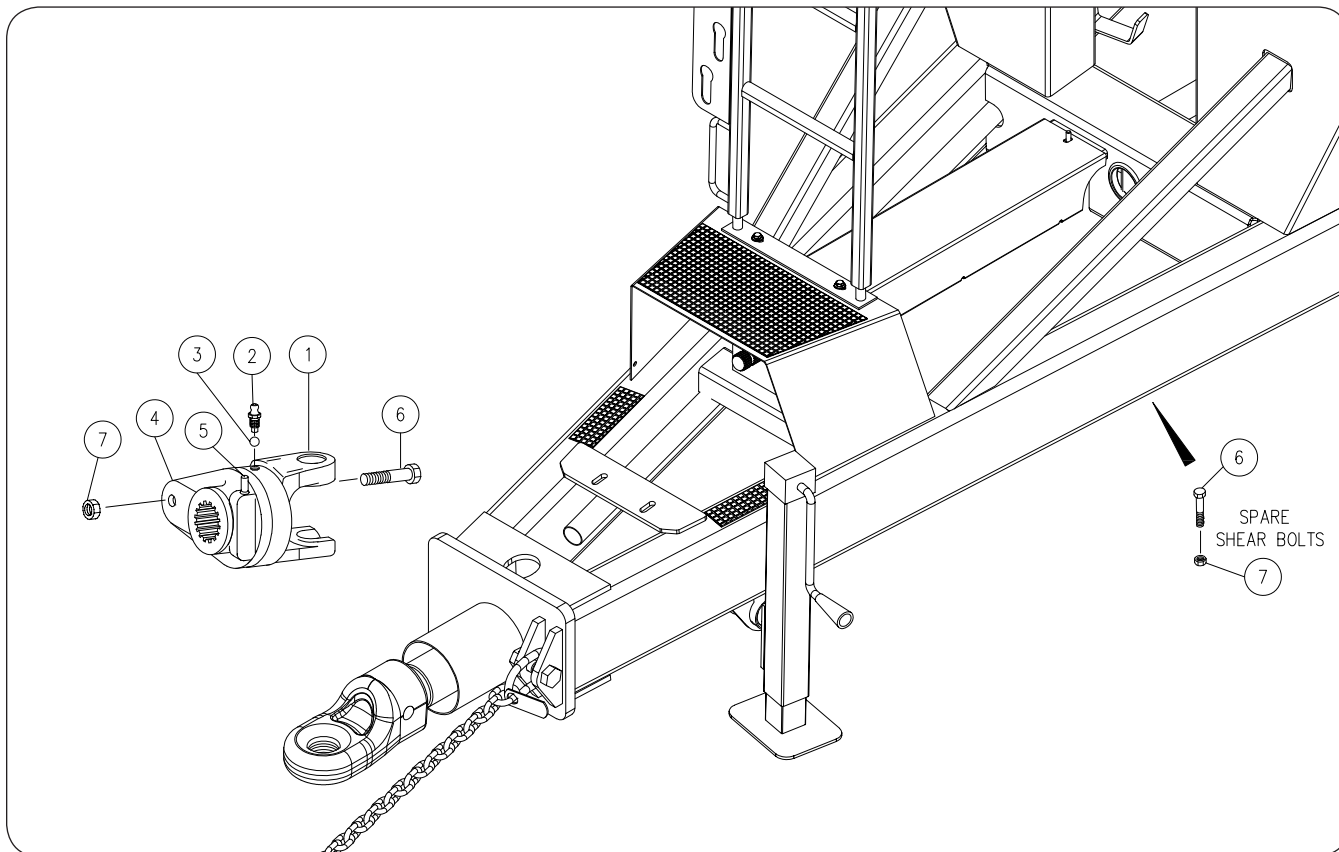

IMPORTANT

- USE GENUINE OEM REPLACEMENT PART. Incorrect part may cause shear function to occur too soon causing inconvenience or too late resulting in damage to driveline and auger components. Tighten to specified torque value.
- Torque to 57 Ft.-Lbs.

ITEM	DESCRIPTION	PART NO.	QTY	NOTES
	Shear-Bolt Clutch	9004170	1	
1	Shear Yoke	9003710	1	
2	Grease Zerk	95256	1	
3	Ball	95257	24	
4	Housing, Splined	9003884	1	
5	Quick Disconnect Pin Kit	92362	1	
6	Bolt, M10 x 60 Gr. 10.9	94910-015	1	Qty. 6 in holder - See note*
7	Locknut, M10	9003645	1	Qty. 6 in holder - See note*

45 Degree Gear Box

Please visit www.unverferth.com/parts/ for the most current parts listing.

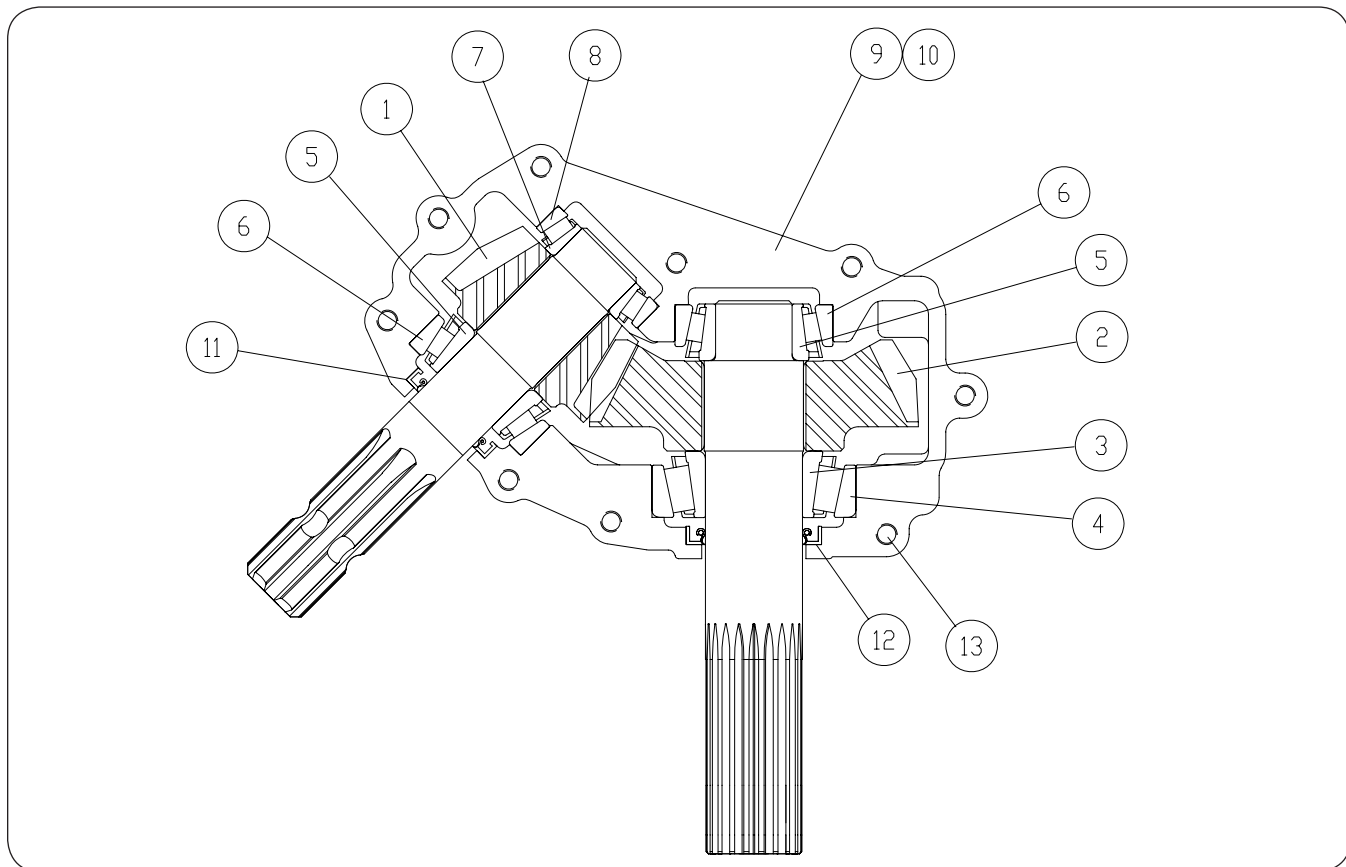

ITEM	DESCRIPTION	PART NO.	QTY.	NOTES
	Gear Box, Complete	9002812	1	Includes Items 1 thru 17
1	Shaft, Input	9001131	1	1.8:1 Gear
2	Shaft, Output	9001132	1	1.8:1 Gear
3	Bearing Cone	92697	1	Large
4	Bearing Cup	91151	1	Large
5	Bearing Cone	9001133	2	
6	Bearing Cup	9001134	2	
7	Bearing Cone	91816	1	Small
8	Bearing Cup	92896	1	Small
9A	Casting w/ Thru Holes - Model Q145 Gearbox	9007299	1	Not Shown
9B	Casting w/ Tapped Holes - Model Q145 Gearbox	9007300	1	Not Shown
10	Gearbox Case Kit - Model Q81	281885	1	Not Shown
11	Seal	92688	1	Small
12	Seal	92702	1	Large
13	Capscrew, 3/8-16 UNC x 1 1/2	95281	9	
14	Pressure Relief, 5-PSI	92352	1	Not Shown
15	Plug, Plain	92350	3	Not Shown
16	Plug, 3/4" Npt	9001139	1	Not Shown
17	Hex Bushing Reducer	9003453	1	Not Shown

Driveline U-Joint Assembly

Please visit www.unverferth.com/parts/ for the most current parts listing.

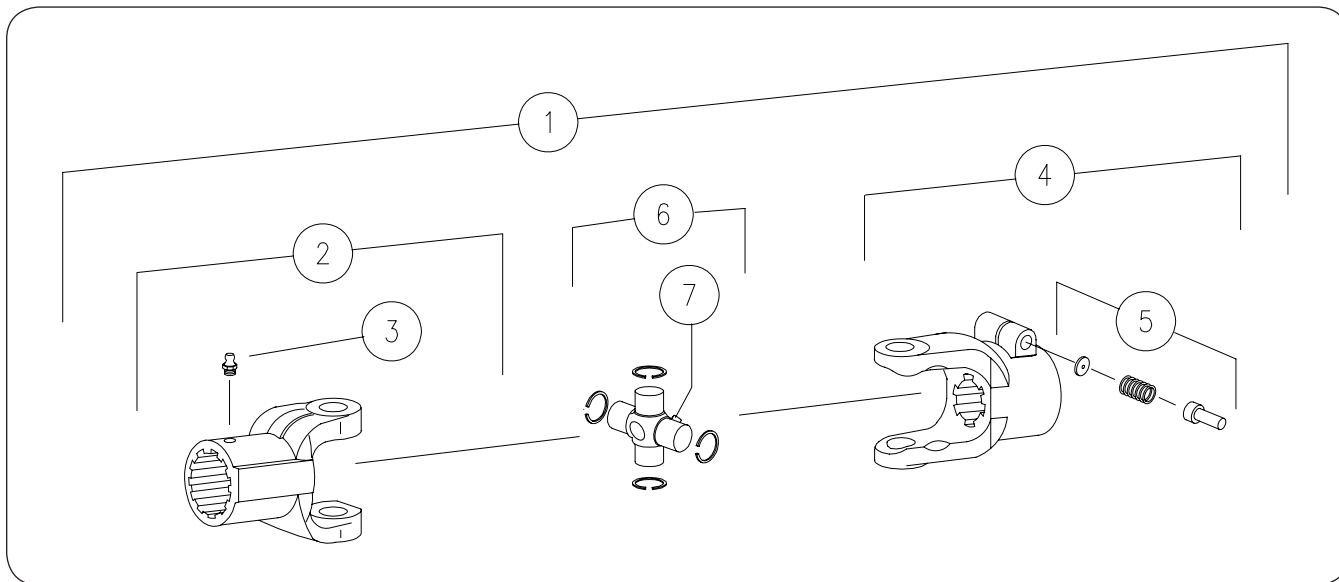

ITEM	DESCRIPTION	PART NO.	QTY.	NOTES
1	Complete U-Joint Assembly	95012	1	
2	Yoke	95010	1	
3	Grease Zerk, 1/4-28 UNF	91160	1	
4	Yoke, 1-3/8-6 Spline	95011	1	
5	Quick Disconnect Pin Kit	92362	1	
6	Cross & Bearing Kit	93857	1	
7	Grease Zerk	92365	1	

Notes

Please visit www.unverferth.com/parts/ for the most current parts listing.

Video System Option

Please visit www.unverferth.com/parts/ for the most current parts listing.

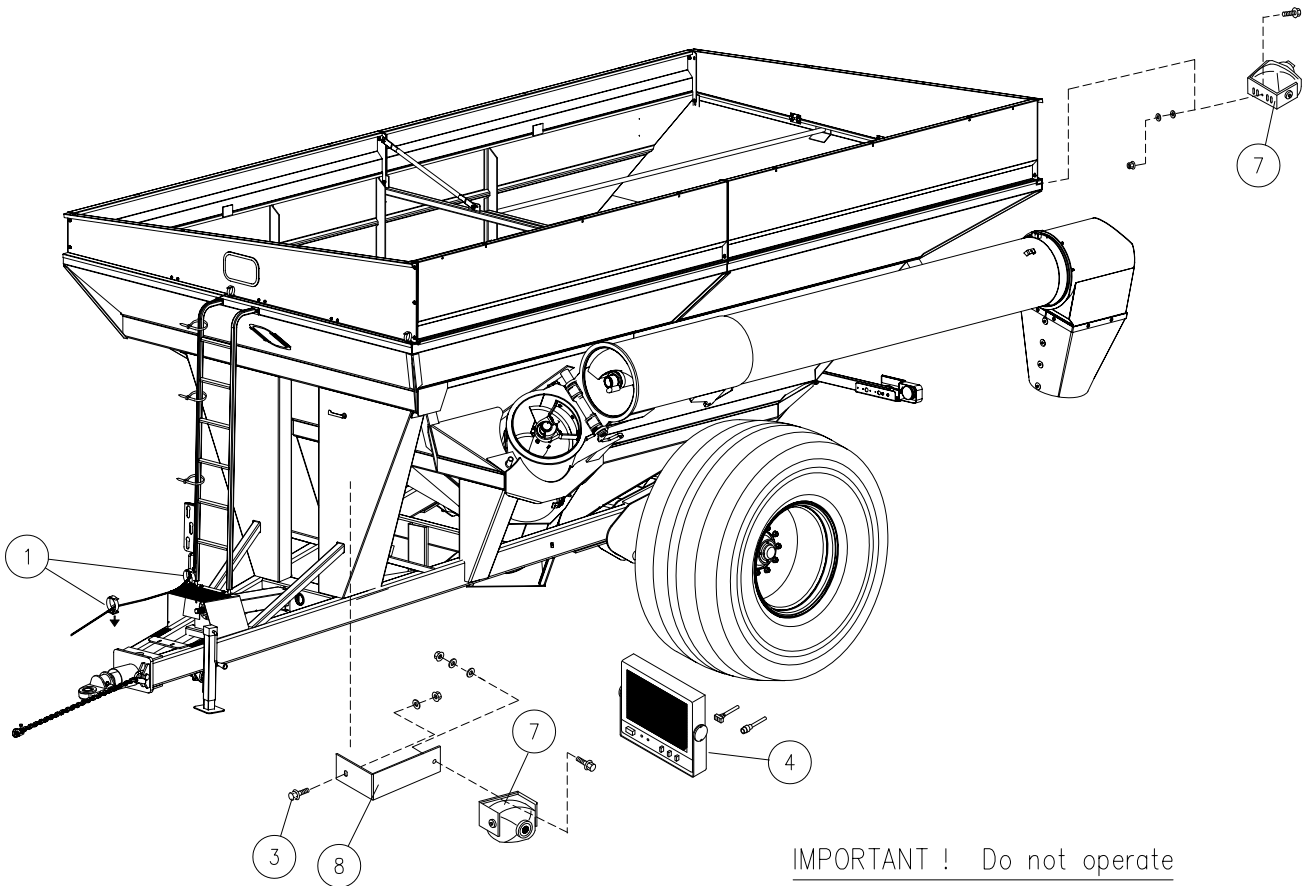

IMPORTANT ! Do not operate Video System below 15° F.

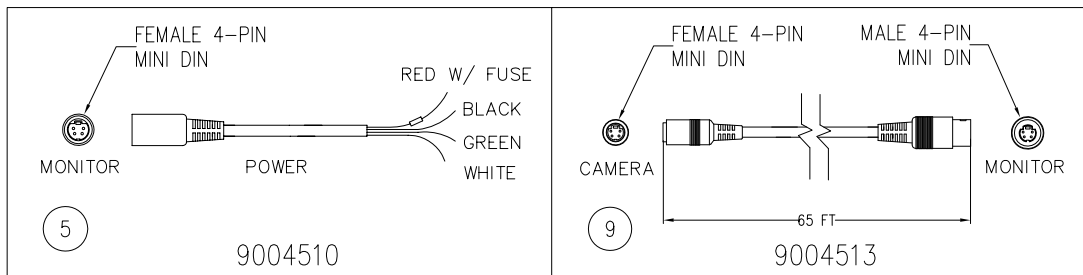

Video System Option

Please visit www.unverferth.com/parts/ for the most current parts listing.

ITEM	PART NO.	DESCRIPTION	QTY	NOTES
	265770	Video System Kit for Front View	1	Includes Items 1,3,4,5,6,7,8
	9004506	Additional Camera for Rear View	1	Includes Items 6 & 7
1	TAAU14007	Snap Clip, Adhesive	10	
3	9512	Self-Drilling Screw 1/4-14 x 1	10	
4	9006273	Monitor, 7" LCD/LED	1	
5	9004510	Cable w/Fuse	1	
7	9006274	Camera	1	
8	265771B	Bracket	1	
9	9004513	Cable, 65'	1	
10	9000106	Cable Tie	AR	
11	284994	Universal Virtual Terminal Camera Kit	1	Not Shown
12	9004506	Camera Kit for Rear View with 65' Cable	1	Not Shown
13	9006909	John Deere 2630 Camera Harness	1	Not Shown
14	9007174	Camera Cable, 16 ft.	1	Not Shown

